



# Bollard & Street Light Project



**PWP-00127**  
**November 2022**

Project Manager  
Chantell O'Neal  
(707) 961-2823 Ext. 131  
[coneal@fortbragg.com](mailto:coneal@fortbragg.com)





## CITY OF FORT BRAGG

*Incorporated August 5, 1889*

416 N. Franklin St.

Fort Bragg, CA 95437

Phone: (707) 961-2823

Fax: (707) 961-2802

<http://city.fortbragg.com>

### COVER LETTER TO PROSPECTIVE BIDDERS

Dear Prospective Bidder:

Enclosed is a complete bid package for the project entitled:

**Bollards and Street Light Project  
Project No. PWP-00127**

This bid package includes the following:

Volume 1 – Bid Forms

Notice Inviting Bids

Bid Form

Bid Bond

Bidder Registration Form

Subcontractors List

Non-Collusion Affidavit

Bidder Certifications

Statement of Qualifications

**[Bidders must complete and return pages 1-11 through 1-34 of Volume 1 Bid Forms]**

Volume 2 – Contract Documents

Contract Check List

Contract, Part 1

Contract, Part 2 – General Provisions

Contract, Part 3 – Special Provisions

Performance Bond

Payment Bond

Maintenance Bond

Certificates of Insurance and Endorsements

Escrow for Security Deposit Agreement (if applicable)

Summary



Volume 3 – Technical Specifications and Project Plans

Technical Specifications  
Project Plan Sheet(s)

The project work is generally described as the furnishing of all labor, equipment and mobilization, and traffic control for the repainting of streetlights, replacement of three (3) missing lights, and installation of bollards and bollard racks as other miscellaneous items in the Central Business District to complete the project, as further described in the bid package. Work shall be completed within 45 Days from the date when Contract Time commences to run.

Sealed completed bids must be received by the City Clerk, or a designee, at the place specified in the Notice Inviting Bids prior to the date and time specified in the Notice Inviting Bids. Any bids that are late according to the official time kept by the City will be returned unopened. Bids that do not conform to the requirements specified in the bid package may be rejected.

Questions regarding the bid package should be directed in writing as soon as possible (but no later than five working days prior to the opening of bids) to:

CITY OF FORT BRAGG  
**Attn: Chantell O'Neal**  
416 North Franklin Street  
Fort Bragg, California 95437  
Phone: 707-961-2823 Ext. 133  
Facsimile: 707-961-2802  
[coneal@fortbragg.com](mailto:coneal@fortbragg.com)





# VOLUME 1



**Bollard & Street Light  
Project  
PWP-00127**





## NOTICE INVITING BIDS

### ARTICLE 1 - INVITATION TO BID

- 1.01 Notice Inviting Bids:** Notice is hereby given that sealed bids will be received by the City Clerk of the City of Fort Bragg ("City"), 416 North Franklin Street, Fort Bragg, California 95437 on or before 2:00 PM, on Friday, December 2, 2022 for the following public work:

**CITY OF FORT BRAGG**  
**Bollard & Street Light Project**  
**PWP-00127**  
**Central Business District**

Bids will be opened and read publicly at 2:00 PM, on Friday, December 2, 2022 via Zoom video conference: <https://us06web.zoom.us/j/81918877212>

- 1.02 Project Description:** Furnish all labor, equipment and mobilization, and traffic control for the repainting of streetlights, replacement of three (3) missing lights, and installation of bollards and bollard racks in the Central Business District. Work shall be completed within 45 Days from the date when Contract Time commences to run.
- 1.03 Engineer's Estimate.** The Engineer's Opinion of Probable Costs is approximately \$ 218,400.00.
- 1.04 Procurement of Bidding Documents:** Bidding Documents contain the full description of the Work. Bidders may examine a complete hard-copy set of the Bidding Documents at the Fort Bragg City Hall, located at 416 North Franklin Street, Fort Bragg, California 95437. For on-line viewing of current bid postings and Project details, go to <https://city.fortbragg.com>. Bidders may obtain electronic Bidding Documents at no cost by emailing Sandy Arellano, [sarellano@fortbragg.com](mailto:sarellano@fortbragg.com) and Chantell O'Neal, [coneal@fortbragg.com](mailto:coneal@fortbragg.com), or by calling (707) 961-2824 on or after November 10, 2022. There will be a \$50.00 non-refundable charge for each printed bid package.
- 1.05 Instructions:** Bidders shall refer to Instructions to Bidders Paragraph 2.03 for required documents and items to be submitted.
- 1.06 [SECTION REMOVED]**
- 1.07 Bid Preparation Cost:** Bidders are solely responsible for the cost of preparing their Bids.
- 1.08 Reservation of Rights:** City specifically reserves the right, in its sole discretion, to reject any or all Bids, to re-bid, or to waive inconsequential defects in bidding not involving time, price or quality of the work. City may reject any and all Bids and waive any minor irregularities in the Bids.

### ARTICLE 2 - LEGAL REQUIREMENTS

- 2.01 Required Contractor's License(s):**
- A. A California class A, class B, OR a class C if they hold all of the following C-10, C-12, and C-33 contractor's license is required to bid this contract. Joint ventures must secure a joint venture license prior to award of this Contract. Specialty work may require a specialty class (contractor's license) held by Bidder or a listed subcontractor. See *Coating and Applicator's Manufacturer's Qualifications* under Technical Specifications Volume 3 of bid packet.
- 2.02 Required Contractor and Subcontractor Registration**
- A. City shall accept Bids only from Bidders that (along with all Subcontractors listed in Subcontractors List) are currently registered with the Department of Industrial Relations ("DIR") and qualified to perform public work pursuant to Labor Code Section 1725.5.
- B. Subject to Labor Code Sections 1771.1(c) and (d), any Bid not complying with paragraph 2.01A above shall be returned and not considered; provided that if Bidder is a joint venture (Business & Professions Code Section 7029.1) or if federal funds are involved in the Contract (Labor Code Section 1771.1(a)), City may accept a non-complying Bid provided that Bidder and all listed Subcontractors are registered at the time of Contract award.
- 2.03 [SECTION REMOVED]**
- 2.04 [SECTION REMOVED]**
- 2.05 Substitution of Securities:** City will permit the successful bidder to substitute securities for any retention monies withheld to ensure performance of the contract, as set forth in Escrow Agreement for Security Deposits in Lieu of Retention and incorporated herein in full by this reference, in accordance with Public Contract Code Section 22300.
- 2.06 Prevailing Wage Laws:** The successful Bidder must comply with all prevailing wage laws applicable to the Project, and related requirements contained in the Contract Documents. Copies

of the general prevailing rates of per diem wages for each craft, classification, or type of worker needed to execute the Contract, as determined by Director of the State of California Department of Industrial Relations, are on file at the City's Public Works Department, may be obtained from the California Department of Industrial Relations website (<http://www.dir.ca.gov/OPRL/dprevagedetermination.htm>) and are deemed included in the Bidding Documents. Upon request, City will make available copies to any interested party. In addition, the successful Bidder shall post the applicable prevailing wage rates at the Site.

**2.07 Prevailing Wage Monitoring:** This Project is subject to prevailing wage compliance monitoring and enforcement by the Department of Industrial Relations.

City of Fort Bragg

Dated: November 10, 2022

By: *June Lemos*  
June Lemos, MMC  
City Clerk

PUBLISH DATE: November 10, 2022

## INSTRUCTIONS TO BIDDERS

Bids are requested by City, for a general construction contract, or work described in general, as set forth in the Notice Inviting Bids in accordance with the following additional terms.

### ARTICLE 1 - PROCEDURES FOR SUBMISSION OF BIDS

#### 1.01 Pre-Bid Conference and Site Visit

- A. City will conduct a Pre-Bid Meeting and Site Visit at the request of the potential bidders.
- B. The Site Visit may be the Bidders' only opportunity to investigate conditions at the Site. Other Pre-Bid Site Visits may be scheduled at City's sole discretion, depending on staff availability.
- C. City will issue Summary Notes of the Pre-Bid Conference, which shall constitute the sole and exclusive record and statement of the results of the Pre-Bid Conference. The Summary Notes issued by City are not Contract Documents.

#### 1.02 Required Pre-Bid Investigations

- A. Prior to submission of Bid, Bidder must conduct a careful examination of Bidding Documents and understand the nature, extent, and location of Work to be performed. Refer to the General Conditions Document on required pre-bid investigations.
- B. Any Bidder wishing to investigate subsurface conditions or otherwise conduct invasive investigations, explorations, test, or studies at this Site before bidding, shall schedule such examinations with City by providing City at least seven (7) days advanced written notice. Additionally, any such Bidder must deliver an executed Access, Indemnity and Release Agreement ("Release") and provide an insurance certificate as described therein by noon of the day prior to the site examination. Bidders who intend only to observe Site conditions and not conduct such examinations are not required to provide an executed Release or an insurance certificate.
- C. Bidders may examine any available existing conditions information (e.g., record documents, specifications, studies, drawings of previous work), as well as applicable environmental assessment information (if any) regarding the Project, by giving City reasonable advanced notice. City will make copies available for a fee. A Bidder must give five (5) days advanced notice if copies are desired.

#### 1.03 Bidder Questions and Answers

- A. Bidders must direct all questions about the meaning or intent of Bidding Documents to City in writing. Interpretations or clarifications considered necessary by City in response to such questions will be issued by written Addenda mailed, emailed, faxed, or delivered to all parties recorded by City as having received Bidding Documents. City may not answer questions received less than **seven (7) Days** prior to the date for opening Bids.
- B. Only questions answered by formal written Addenda will be binding. Any other interpretations or clarifications will be without legal effect, and Bidders shall not rely on oral statements.

#### 1.04 Addenda

- A. Addenda may also be issued to modify the Bidding Documents as deemed advisable by City. Addenda shall be acknowledged by number in the Bid Form and shall be part of the Contract Documents. A complete listing of Addenda may be secured from City.

### ARTICLE 2 - RECEIPT OF BIDS

#### 2.01 Date and Time

- A. Sealed Bids will be received by the City until the date and time indicated in the Notice Inviting Bids. All Bid envelopes will be time-stamped to reflect their submittal time. City shall reject all Bids received after the specified time and will return such Bids to Bidders unopened. Bidders must submit Bids in accordance with this Instructions to Bidders Document.

#### 2.02 Bid Submission

- A. City will receive Bids in opaque sealed envelopes, containing the required items described herein under Section 2.03, Required Contents of "Bid Submittals."
- B. Bidders should mark their Bid envelopes using their name, address, identifying information and project number indicated in Notice Inviting Bids.

#### 2.03 Required Contents of "Bid Submittals"

- A. Bid Form. Bidders must submit Bids on the City's Bid Form. Bidders must complete all Bid items and supply all information required by Bid documents and specifications.

- B. Bond Accompanying Bid. Bidders must submit a completed Bond Accompanying Bid document (surety bond), cash, cashier's check or certified check (certified without qualification and drawn on a solvent bank of the State of California or a National Bank doing business in the State of California) in an amount not less than 10% of the base Bid, payable to City of Fort Bragg.
- C. Bidder Registration Form. Bidders must submit a completed Bidder Registration Form.
- D. Subcontractors List. Bidders must submit a Subcontractors List. The Subcontractors List must include the names, location, place of business, and other information required therein, for all subcontractors who will perform any portion of work, including labor, rendering of service, or specially fabricating and installing a portion of the work or improvement according to detailed drawings contained in the plans and specifications, in excess of one half of one percent (0.5%) of the total Bid amount. Any violation of this requirement may result in a Bid being deemed non-responsive and not being considered.
- E. Non-Collusion Affidavit. Bidders must submit a completed Non-Collusion Affidavit.
- F. Bidder Certifications. Bidders must submit a completed Bidder Certification.
- G. Additional Qualification Information. Applicator Qualifications (p 1) Technical Specs. If Bidder is required to submit Additional Qualification Information as required Bidder Certifications, Bidder shall provide such information as follows:
  1. Include on first page (or separate cover sheet) the words "Additional Qualification Information."
  2. All Additional Qualification Information items must reference the original Qualification Information they are revising.
  3. The Additional Qualification Information must be contained in a **separate** sealed envelope, labeled "Additional Qualification Information."
  4. Notwithstanding any other provision of these Instructions to Bidders, City will only open a Bidder's Additional Qualification envelope if Bidder is an Apparent Low Bidder.
- H. Statement of Qualifications for Construction Work. Bidder must submit a Statement of Qualifications for Construction Work.

### **ARTICLE 3 - BID OPENING AND EVALUATION**

#### **3.01 Determination of Apparent Low Bidder**

- A. City will open each Bidder's Envelope at the time and place indicated in the Notice Inviting Bids, initially evaluate them for responsiveness, and determine an Apparent Low Bidder as specified herein.
- B. Apparent Low Bid will be determined solely on the Total Bid Price based on terms contained in the Notice Inviting Bids and the Bid Form. All Bidders are required to submit Bids on all Bid items (including any alternates).
- C. For the Apparent Low Bidder only, City will evaluate the Apparent Low Bidder for responsiveness to the requirements of the Statement of Qualifications for Construction Work form and for Responsibility.
- D. If Apparent Low Bidder is determined to be non-responsive or non-responsible, then City may proceed to the next Apparent Low Bidder's Bid pursuant to any procedures determined in its reasonable discretion, and proceed for all purposes as if this Apparent Low Bidder were the original Apparent Low Bidder.

#### **3.02 Evaluation of Bids**

- A. Bids must be full, complete, clearly written and using the required forms. Bidders shall make any change in the Bid by crossing out the original entry, entering and initialing the new entry. Bidder's failure to submit all required documents strictly as required entitles City to reject the Bid as non-responsive. All Bidders must submit Bids containing each of the fully executed documents supplied in these bid documents.
- B. In evaluating Bids, City will consider Bidders' qualifications, whether or not the Bids comply with the prescribed requirements, unit prices, and other data, as may be requested in the Bid Form or prior to the Notice of Award.
- C. City may conduct reasonable investigations and reference checks of Bidder and other persons and organizations as City deems necessary to assist in the evaluation of any Bid and to establish Bidder's responsibility, qualifications, financial ability, and capability to perform the Work in

accordance with the Contract Documents to City's satisfaction within the prescribed time. Submission of a Bid constitutes Bidder's consent to the foregoing.

- D. City shall have the right to consider information provided by sources other than Bidder. City shall also have the right to communicate directly with Bidder's surety regarding Bidder's bonds.
- E. Discrepancies between the multiplication of units of Work and unit prices will be resolved in favor of the unit prices. Discrepancies between the indicated sum of any column of figures and the correct sum thereof will be resolved in favor of the correct sum. Discrepancies between written words and figures will be resolved in favor of the words.
- F. Bids shall be deemed to include the written responses of the Bidder to any questions or requests for information of City made as part of Bid evaluation process after submission of Bid.

**3.03 Reservation of Rights**

- A. City reserves the right to:
  - 1. Reject any or all nonconforming, non-responsive, unbalanced, or conditional Bids, and
  - 2. Reject the Bid of any Bidder as non-responsive as a result of any error or omission in the Bid, and
  - 3. Reject the Bid of any Bidder if City believes that it would not be in the best interest of the Project to make an award to that Bidder, whether because the Bid is not responsive, the Bidder is unqualified or of doubtful financial ability, or fails to meet any other pertinent standard or criteria established by City.
- B. For purposes of this paragraph, an "unbalanced Bid" is one having nominal prices for some Bid items and enhanced prices for other Bid items.
- C. City may retain Bid securities and Bid bonds of other than the Apparent Low Bidder for a period of 120 Days after award or full execution of the Contract, whichever first occurs.
- D. City may waive any informalities or minor irregularities in the Bids.
- E. City also reserves the right, in its discretion, to reject any or all Bids and to re-Bid the Project.

**3.04 Required Contractor and Subcontractor Registration**

- A. City shall accept Bids only from Bidders that (along with all Subcontractors listed in the Subcontractors List) are currently registered with the Department of Industrial Relations and qualified to perform public work pursuant to Labor Code Section 1725.5.
- B. Subject to Labor Code Sections 1771.1(c) and (d), any Bid not complying with paragraph 3.04.A above, shall be returned and not considered; provided that if Bidder is a joint venture (Business & Professions Code Section 7029.1) or if federal funds are involved in the Contract (Labor Code Section 1771.1(a)), City may accept a non-complying Bid provided that Bidder and all listed Subcontractors are registered at the time of Contract award.

**ARTICLE 4 - MANDATORY BID PROTEST PROCEDURES**

**4.01 Submission of Written Bid Protest**

- A. Any Bid protest in connection with the construction contract or work described in general in the Notice Inviting Bids must be submitted in writing to the **City Clerk, City of Fort Bragg, 416 North Franklin Street, Fort Bragg, California 95437**, before **3:30 p.m.** of the fifth Business Day following the Bid opening.
- B. The initial protest document must contain a complete statement of the basis for the protest.
- C. The protest must refer to the specific portion of the document that forms the basis for the protest.
- D. The protest must include the name, address, and telephone number of the person representing the protesting party.
- E. Only Bidders who the City otherwise determines are responsive and responsible are eligible to protest a Bid; protests from any other Bidder will not be considered. In order to determine whether a protesting Bidder is responsive and responsible, City may evaluate all information contained in any protesting Bidder's Bid, and conduct the same investigation and evaluation as City is entitled to take regarding an Apparent Low Bidder.
- F. The party filing the protest must concurrently transmit a copy of the initial protest document and any attached documentation to all other parties with a direct financial interest that may be adversely affected by the outcome of the protest. Such parties shall include all other Bidders who appear to have a reasonable prospect of receiving an award depending upon the outcome of the protest.

**4.02 Exclusive Remedy**

- A. The procedure and time limits set forth in this Article 4 are mandatory and are Bidder's sole and exclusive remedy in the event of Bid protest. Bidder's failure to comply with these procedures shall constitute a waiver of any right to further pursue the Bid protest, including filing a Government Code Claim or other legal proceedings. A Bidder may not rely on a protest submitted by another Bidder, but must timely pursue its own protest.

## **ARTICLE 5 - AWARD AND EXECUTION OF CONTRACT**

### **5.01 Notice of Award and Submittal of Executed Contract Documents**

- A. If Contract is to be awarded, it will be awarded to the lowest responsible responsive Bidder. City will issue a Notice of Award. Such Award, if made, will be made within ninety (90) days after the opening of the Bid Proposals.
- B. Successful Bidder must execute and submit to City the "Required Contract Documents and Proof of Insurance" set forth below, by 5:00 p.m. of the tenth (10<sup>th</sup>) working Day following the Notice of Award.

### **5.02 Required Contract Documents and Proof of Insurance**

- A. Agreement, fully executed by successful Bidder. Submit two originals, each bearing an original, notarized signature on the signature page.
- B. Construction Performance Bond, fully executed by successful Bidder and surety, in the amount set forth in that document. Submit one original.
- C. Construction Labor and Material Payment Bond, fully executed by successful Bidder and surety, in the amount set forth in that document. Submit one original.
- D. Insurance certificates and endorsements, required by Supplementary Conditions—Insurance. Submit one original set.
- E. Any other items identified by City in its Notice of Award.

### **5.03 Failure to Execute and Deliver Documents**

- A. If Bidder to whom the Contract is awarded, within the period described in the Instructions to Bidders, fails or neglects to execute and deliver all required Contract Documents and file all required bonds, insurance certificates, and other documents, City may, in its sole discretion, rescind the award, recover on Bidder's surety bond, or deposit Bidder's cashier's check or certified check for collection, and retain the proceeds thereof as liquidated damages for Bidder's failure to enter into the Contract Documents. Bidder agrees that calculating the damages City may suffer as a result of Bidder's failure to execute and deliver all required Contract Documents would be extremely difficult and impractical and that the amount of Bidder's required Bid security shall be the agreed and presumed amount of City's damages.
- B. Upon Bidder's failure to timely deliver all required Contract Documents as set forth herein, City may determine the next Apparent Low Bidder and proceed accordingly.

## **ARTICLE 6 - GENERAL CONDITIONS AND REQUIREMENTS**

### **6.01 Modification of Commencement of Work**

- A. City expressly reserves the right to modify the date for the Commencement of Work under the Contract and to independently perform and complete work related to Project. City accepts no responsibility to Contractor for any delays attributed to its need to complete independent work at the Site.
- B. City shall have the right to communicate directly with Apparent Low Bidder's proposed performance bond surety, to confirm the performance bond. City may elect to extend the time to receive faithful performance and labor and material payment bonds.

### **6.02 Conformed Project Manual**

- A. Following Award of Contract, City may prepare a conformed Project Manual reflecting Addenda issued during bidding, which will, failing objection, constitute the approved Project Manual.

### **6.03 Payment Bond**

- A. If the Project described in the Notice Inviting Bids involves an expenditure in excess of twenty-five thousand dollars (\$25,000), the successful Bidder must file a payment bond with and approved by City prior to entering upon the performance of the Work, in accordance with Civil Code Section 9550, *et seq.*

### **6.04 Wage Rates**

- A. Copies of the general prevailing rates of per diem wages for each craft, classification, or type of worker needed to execute the Contract, as determined by Director of the State of California

Department of Industrial Relations, are on file at the City's Public Works Department and may be obtained from the California Department of Industrial Relations website <http://www.dir.ca.gov/OPRL/DPreWageDetermination.htm> and are deemed included in the Bidding Documents. Upon request, City will make available copies to any interested party. Also, Contractor shall post the applicable prevailing wage rates at the Site.

**6.05 Withdrawal of Bids**

- A. Bidders may withdraw their Bids at any time prior to the Bid opening time fixed in the Instructions to Bidders, only by written request for the withdrawal of Bid filed with City at the **City Clerk's office located at 416 North Franklin Street, Fort Bragg, California**. Bidder or its duly authorized representative shall execute request to withdraw Bid.

**6.06 Ineligible Contractors and Subcontractors**

- A. City will reject a Bid from a Bidder who is ineligible to bid or work on, or be awarded, a public works project pursuant to Labor Code Section 1777.1 or 1777.7. Bidders and the Contractor who is awarded the project contract shall not utilize, or allow work by, any subcontractor who is ineligible to bid or work on, or be awarded, a public works project pursuant to Labor Code Section 1777.1 or 1777.7. (See Public Contract Code Section 6109.) The California Division of Labor Standards Enforcement publishes a list of debarred contractors and subcontractors on the Internet at [www.dir.ca.gov/DLSE/debar.html](http://www.dir.ca.gov/DLSE/debar.html).

**6.07 Public Records Act Requests**

- A. In accordance with the California Public Records Act, City will make available to the public Bidder's Statement of Qualifications ("SOQ"), correspondence and written questions submitted during the Bid period, all Bid submissions opened in accordance with the procedures set forth herein, and all subsequent Bid evaluation information. All submissions not opened will remain sealed and shall be returned to the submitter. Except as otherwise required by law, City will not disclose trade secrets or proprietary financial information submitted by Bidders that has been designated as confidential by Bidder (including, without limitation, the SOQ). Any such trade secrets or proprietary financial information that Bidder believes should be exempted from disclosure shall be specifically identified and marked as such. Blanket-type identification by designating whole pages or sections shall not be permitted and shall be invalid. The specific confidential information must be clearly identified as such.
- B. Upon a request for records regarding this Bid, City will notify the Bidder involved, within ten Days from receipt of the request, when the records will be made available for inspection. If the Bidder timely identifies any "proprietary, trade secret, or confidential commercial or financial" information that Bidder determines is not subject to public disclosure, and requests that City refuse to comply with the records request, Bidder will, at its sole expense, take all appropriate legal action and defend City's refusal to produce the information in all forums; otherwise City will make such information available to the extent required by applicable law, without restriction.
- C. Information disclosed in the Statement of Qualifications and the attendant opened submissions are the property of City unless Bidder makes specific reference to data that is considered proprietary. Subject to the requirements in the Public Records Act, reasonable efforts will be made to prevent the disclosure of information except on a need-to-know basis during the evaluation process.

**6.08 Substitutions**

- A. Bidders must base their Bids on products and systems specified in Contract Documents or listed by name in Addenda. City will consider substitution requests only for "or equal items." Bidders wanting to use "or equal" item(s) may submit a Substitution Request Form no later than thirty-five (35) Days after Notice of Award. To assess "or equal" acceptability of product or system, request(s) for substitution must contain the information required in the Substitution Request Form. Insufficient information will be grounds for City to reject the substitution. City will, within a reasonable time, after having received a request for substitution, issue in writing its decision as to whether the proposed substitution is an "or equal" item compatible to City systems, durability, and quality. City's decision shall be conclusive as to all Bidders. Prior to bid, requests for substitution will not be considered unless the Substitution Request Form is received at least seven (7) Days prior to Bid day. Substitutions approved before Bid day will be listed in Addenda and become part of the Contract Documents.

As a limitation on Bidder's privilege to request substitution of "or equal" items, City has found that certain items are designated as City standards and certain items are designated to match existing items in use on a particular public improvement either completed or in the course of completion or are available from one source. As to such items, City will not permit substitution. Such items (if any) are described in Notice Inviting Bids.



## **GEOTECHNICAL DATA AND EXISTING CONDITIONS**

### **ARTICLE 1 - REPORTS AND INFORMATION ON EXISTING CONDITIONS**

#### **1.01 Inspection of Reports**

- A. City, its consultants, and prior contractors may have collected documents providing a general description of the Site and conditions of the Work. These documents may consist of geotechnical reports for and around the Site, contracts, contract specifications, tenant improvement contracts, as-built drawings, utility drawings, information regarding Underground Facilities, and hazardous material surveys or information (collectively, Existing Conditions Data).
- B. Bidders may inspect Geotechnical and Existing Conditions Data. These documents are listed in Summary of Work and are available for review at the address identified therein. Copies may be obtained for the cost of reproduction and handling upon Bidder's payment for the costs.
- C. Existing Conditions Data is for information purposes only and does not describe labor, materials or equipment furnished by Contractor, but rather, information regarding conditions of the work. Such Existing Conditions Data is not a Contract Document.

### **ARTICLE 2 - USE OF EXISTING CONDITIONS DATA**

#### **2.01 Above-Ground Existing Conditions**

- A. City makes no warranty or representation of existing aboveground conditions, as-built conditions, or other aboveground actual conditions verifiable by reasonable independent investigation. These conditions are verifiable by Bidder by the performance of its own independent investigation that Bidder must perform prior to bidding and Bidder must not rely on the information supplied by City regarding such existing conditions.
- B. Bidder represents and agrees that in submitting its Bid, it is not relying on any information regarding above-ground existing conditions supplied by City.

#### **2.02 Underground Facilities**

- A. Information supplied regarding existing Underground Facilities at or contiguous to the Site is based on information furnished to City by others (e.g., the builders of such Underground Facilities or others).
- B. City assumes responsibility for only the general accuracy, completeness or thoroughness of information regarding Underground Facilities that are owned by City. This express assumption of responsibility applies only if Bidder has conducted the independent investigation required of it under the General Conditions of the Contract and discrepancies were not apparent. Bidder is solely responsible for any interpretation or conclusion drawn from this information. City is not responsible for information regarding Underground Facilities that are owned by others.

#### **2.03 Hazardous Materials Surveys**

- A. Bidders may rely on this data and information for general accuracy regarding the locations of potentially hazardous materials. City does not warrant and makes no representation regarding the completeness or thoroughness of any data or information regarding existing conditions or hazardous materials including, without limitation, quantities, characteristics, volumes, or associated structural features. Bidder represents and agrees that in submitting a Bid it is not relying on any such data, information or deductions.
- B. Data and information regarding the locations of hazardous materials are not part of Contract Documents.

#### **2.04 Geotechnical Data**

- A. Bidder may rely upon the general accuracy of the "technical data" contained in the geotechnical reports and drawings identified above, but only insofar as it relates to subsurface conditions, provided Bidder has conducted the independent investigation required of it and discrepancies were not apparent.
- B. The term "technical data" shall include actual reported depths, reported quantities, reported soil types, reported soil conditions, and reported material, equipment, or structures that were encountered during subsurface exploration. The term "technical data" does not include, and Bidder may not rely upon, any other data, interpretations, opinions or information shown or indicated in such drawings or reports that otherwise relate to subsurface conditions or described structures. The term "technical data" shall not include the location of Underground Facilities.

- C. Bidder may not rely on the completeness of reports and drawings for the purposes of bidding or construction. Bidder is solely responsible for any interpretation or conclusion drawn from any "technical data" or any other data, interpretations, opinions, or information contained in supplied geotechnical data.

**2.05 Representations**

- A. Except as expressly set forth herein, City does not warrant, and makes no representation regarding, the accuracy or thoroughness of any geotechnical and existing conditions data.
- B. Bidder represents and agrees that in submitting its Bid, it is not relying on any geotechnical and existing conditions data supplied by City, except as specifically set forth herein.

**ARTICLE 3 - INVESTIGATIONS**

**3.01 Required Investigations**

- A. Before submitting a Bid, each Bidder shall be responsible to obtain such additional or supplementary examinations, investigations, explorations, tests, studies and data concerning conditions (surface, subsurface, and Underground Facilities) at or contiguous to the Site or otherwise, which may affect cost, progress, performance or furnishing of Work or which relate to any aspect of the means, methods, techniques, sequences or procedures of construction to be employed by Bidder and safety precautions and programs incident thereto or which Bidder deems necessary to determine its Bid for performing and furnishing the Work in accordance with the time, price and other terms and conditions of Contract Documents.
- B. Bidders shall advise City in writing during the Bid period of any questions, suppositions, inferences or deductions Bidders may have for City's review and response.
- C. City has provided time in the period prior to bidding for Bidder to perform these investigations.

**3.02 Access to Site for Investigations**

- A. During the Pre-Bid Site Visit(s), City will provide each Bidder access to the Site to conduct such examinations, investigations, explorations, tests, and studies, as each Bidder deems necessary for submission of a Bid, provided that invasive testing will be permitted only to the extent provided in the Instructions to Bidders, and provided that each Bidder seeking access to conduct such investigations provides a signed Access, Indemnity and Release Agreement. Bidders must fill all holes and clean up and restore the Site to its former conditions upon completion of such explorations, investigations, tests, and studies. Such investigations may be performed only under the provisions of these Instructions to Bidders and the General Conditions of the Contract including, without limitation, proof of insurance and obligation to indemnify against claims arising from such investigation work. Each Bidder shall supply all equipment required to perform any investigations as each Bidder deems necessary. City has the right to limit the number of pieces of machinery operating at any one time due to safety concerns or in order to protect or maintain the Site from potential damage or interruption to general operational activities.

**BID FORM  
TO THE CITY OF FORT BRAGG**

**THIS BID IS SUBMITTED BY:**

---

(Firm/Company Name)

Re: **Bollard and Street Lights Project, PWP-00127** in Fort Bragg, California.

1. The undersigned Bidder proposes and agrees, if this Bid is accepted, to enter into an Agreement with the **CITY OF FORT BRAGG** in the form included in the Contract Documents (Agreement), to perform and furnish all Work as specified or indicated in the Contract Documents for the Contract Sum and within the Contract Time indicated in this Bid and in accordance with all other terms and conditions of the Contract Documents.
2. Bidder accepts all of the terms and conditions of the Contract Documents, Notice Inviting Bids, and Instructions to Bidders, including, without limitation, those dealing with the disposition of Bid Security. This Bid will remain subject to acceptance for 60 Days after the day of Bid opening, unless there is a bid protest, then 90 days after the day of bid opening.
3. In submitting this Bid, Bidder represents that Bidder has examined all of the Contract Documents, performed all necessary Pre-Bid investigations, attended the mandatory Pre-Bid Meeting, if any, received the Pre-Bid Meeting Summary Notes (if any), and received the following Addenda:

Addendum Number	Addendum Date	Signature of Bidder

4. Based on the foregoing, Bidder proposes and agrees to fully perform the Work within the time stated and in strict accordance with the Contract Documents for the following sums of money listed in the following Schedule of Bid Prices.

**SCHEDULE OF BID PRICES**

All Bid items, including lump sums, unit prices and alternates (if any), must be filled in completely. Bid items are described in Summary of Work. Quote in figures only, unless words are specifically requested.

Item	Description	Estimated Quantity	Unit	Unit Price	Total
1	Install Bollard	71	EA	\$	\$
2	Replace Existing Damaged or Missing Light Pole	3	EA	\$	\$
3	Paint Street Light	71	EA	\$	\$
4	Bollard Storage Rack (Capacity: 2)	1	EA	\$	\$
5	Bollard Storage Rack (Capacity: 4)	1	EA	\$	\$
6	Bollard Storage Rack (Capacity: 6)	11	EA	\$	\$
7	All Work of Contract Documents other than Work separately provided for under other Bid items	1		\$	\$
				<b>TOTAL BASE BID PRICE</b>	\$

**TOTAL BASE BID PRICE:**

---

(Indicate Bid Price in Words)

---

(Indicate Bid Price in Dollar Figures)

1. The undersigned acknowledges that the Apparent Low Bidder will be determined as provided in Notice to Bidders and Instructions to Bidders.
2. Subcontractors for work are listed in Subcontractors List, submitted herewith.
3. The undersigned Bidder understands that City reserves the right to reject this Bid.
4. If written notice of the acceptance of this Bid, hereinafter referred to as Notice of Award, is mailed or delivered to the undersigned Bidder within the time described in Paragraph 2 of this Document or at any other time thereafter before it is withdrawn, the undersigned Bidder will execute and deliver the documents required by Instructions to Bidders within the times specified therein.
5. Notice of Award or request for additional information may be addressed to the undersigned Bidder at the address set forth below.
6. The undersigned Bidder herewith encloses cash, a cashier's check, or certified check of or on a responsible bank in the United States, or a corporate surety bond furnished by a surety authorized to do a surety business in the State of California, in form specified in the Instructions to Bidders, in the amount of ten percent (10%) of the Total Bid Price and made payable to the **CITY OF FORT BRAGG**.

7. The undersigned Bidder agrees to commence Work under the Contract Documents on the date established in the Agreement's General Conditions and to complete all Work within the time specified in the Agreement.
8. The undersigned Bidder agrees that, in accordance with the General Conditions, liquidated damages for failure to complete all Work in the Contract within the time specified in the Agreement shall be as set forth therein.

**IMPORTANT NOTICE:** If Bidder or other interested person is a corporation, give the legal name of the corporation, state where incorporated, and names of president and secretary thereof; if a partnership, give name of the firm and names of all individual co-partners composing the firm; if Bidder or other interested person is an individual, give first and last names in full.

**NAME OF BIDDER:** \_\_\_\_\_

is licensed in accordance with an act for the registration of Contractors, with license number:

\_\_\_\_\_ Expiration date: \_\_\_\_\_.

I certify (or declare) under penalty of perjury under the laws of the State of California that the foregoing is true and correct.

\_\_\_\_\_  
(Signature of Bidder)

Date of Bid: \_\_\_\_\_  
(Date)

Business Address: \_\_\_\_\_  
\_\_\_\_\_  
\_\_\_\_\_

Email Address: \_\_\_\_\_

**NOTE:** If Bidder is a corporation, set forth the legal name of the corporation together with the signature of the officer or officers authorized to sign contracts on behalf of the corporation. If Bidder is a partnership, set forth the name of the firm together with the signature of the partner or partners authorized to sign contracts on behalf of the partnership.

\_\_\_\_\_  
(Place of Incorporation, if Applicable) \_\_\_\_\_  
(Principal)

\_\_\_\_\_  
(Principal)

\_\_\_\_\_  
(Principal)

Contractor's Representative(s): \_\_\_\_\_  
(Name/Title)

---

(Name/Title)

---

(Name/Title)

Officers Authorized to Sign Contracts

---

(Name/Title)

---

(Name/Title)

---

(Name/Title)

Telephone Number(s):

---

(Area Code) (Number)

---

(Area Code) (Number)

Fax Number(s):

---

(Area Code) (Number)

---

(Area Code) (Number)

**BOND ACCOMPANYING BID**

KNOW ALL PERSONS BY THESE PRESENTS:

That the undersigned

\_\_\_\_\_  
(Name of Contractor)

as Principal and the undersigned as Surety are held and firmly bound unto **CITY OF FORT BRAGG, a California Municipal Corporation** ("City"), as obligee, in the penal sum of **(Dollar Amount In Words)** \_\_\_\_\_ Dollars (**\$** \_\_\_\_\_) lawful money of the United States of America being at least ten percent (10%) of the aggregate amount of said Principal's base Bid, for the payment of which, well and truly to be made, we bind ourselves, our successors, executors, administrators, and assigns, jointly and severally, firmly by these presents.

WHEREAS, said Principal is submitting a Bid for City Contract Number **PWP-00127, Bollard and Street Lights Project in the Downtown Business District, Fort Bragg, CA.**

THE CONDITION OF THIS OBLIGATION IS SUCH that if the Bid submitted by the said Principal be accepted and the Contract be awarded to said Principal and said Principal shall within the required periods enter into the Contract so awarded and provide the required Construction Performance Bond, Construction Labor and Material Payment Bond, insurance certificates, and all other endorsements, forms, and documents required under Instructions to Bidders, then this obligation shall be void, otherwise to remain in full force and effect.

IN WITNESS WHEREOF, the above parties have executed this instrument this \_\_\_\_\_ day of \_\_\_\_\_, 20\_\_\_\_.

(Corporate Seal)

By \_\_\_\_\_  
Principal

By \_\_\_\_\_  
Surety

(Corporate Seal)

By \_\_\_\_\_  
Attorney in Fact

**THIS PAGE INTENTIONALLY LEFT BLANK**



**BIDDER REGISTRATION FORM**

**INDEPENDENT CONTRACTOR REGISTRATION**

Contractor's License # \_\_\_\_\_

Date: \_\_\_\_\_ Fed Tax I.D. # \_\_\_\_\_

Contractor's DIR Registration # \_\_\_\_\_

Full Corporate Name of Company: \_\_\_\_\_

Street Address: \_\_\_\_\_

\_\_\_\_\_

Mailing Address: \_\_\_\_\_

\_\_\_\_\_

Phone: \_\_\_\_\_ Fax: \_\_\_\_\_

Name of Principal Contact: \_\_\_\_\_

Email Address: \_\_\_\_\_

Type of Business:                    \_\_\_\_\_ Sole Proprietor                    \_\_\_\_\_ Partnership  
   \_\_\_\_\_ Non-Profit 501(c)(3)                    \_\_\_\_\_ Corporation  
   \_\_\_\_\_ other (please explain: \_\_\_\_\_)

**INSURANCE** (Complete all items listed below that are applicable and/or are required by Supplementary Conditions – Insurance and Indemnification)

**Workers' Compensation:**

Carrier: \_\_\_\_\_

Address: \_\_\_\_\_

Phone and Fax: \_\_\_\_\_

Policy Number: \_\_\_\_\_

**General Liability:**

Carrier: \_\_\_\_\_

Address: \_\_\_\_\_

Phone and Fax: \_\_\_\_\_

Policy Number: \_\_\_\_\_

Policy Limits: \$ \_\_\_\_\_

A.M. Best Rating: \_\_\_\_\_

**Automobile Liability:**

Carrier: \_\_\_\_\_

Address: \_\_\_\_\_

Phone and Fax: \_\_\_\_\_

Policy Number: \_\_\_\_\_

Policy Limits: \$ \_\_\_\_\_

A.M. Best Rating: \_\_\_\_\_

**Professional Liability (IF APPLICABLE):**

Carrier: \_\_\_\_\_

Address: \_\_\_\_\_

Phone and Fax: \_\_\_\_\_

Policy Number: \_\_\_\_\_

Policy Limits: \$ \_\_\_\_\_

A.M. Best Rating: \_\_\_\_\_

**Excess Liability Insurance (IF APPLICABLE)**

Carrier: \_\_\_\_\_

Address: \_\_\_\_\_

Phone and Fax: \_\_\_\_\_

Policy Number: \_\_\_\_\_

Policy Limits: \$ \_\_\_\_\_

A.M. Best Rating: \_\_\_\_\_

**Other Liability Insurance (IF APPLICABLE):**

Carrier: \_\_\_\_\_

Address: \_\_\_\_\_

Phone and Fax: \_\_\_\_\_

Policy Number: \_\_\_\_\_

Policy Limits: \$ \_\_\_\_\_

A.M. Best Rating: \_\_\_\_\_

**BIDDER CERTIFIES, UNDER PENALTY OF PERJURY, THAT THE FOREGOING INFORMATION IS CURRENT AND ACCURATE AND AUTHORIZES CITY, AND ITS AGENTS AND REPRESENTATIVES TO OBTAIN A CREDIT REPORT AND/OR VERIFY ANY OF THE ABOVE INFORMATION.**

BIDDER: \_\_\_\_\_  
(COMPANY NAME)

By: \_\_\_\_\_ TITLE \_\_\_\_\_  
NAME

By: \_\_\_\_\_ DATE \_\_\_\_\_  
SIGNATURE

**THIS PAGE INTENTIONALLY LEFT BLANK**

**SUBCONTRACTORS LIST**

*[See Instructions to Bidders paragraph 2.03.D]*

Subcontractor Name and Business Location	Description of Work	Subcontract Amount	Subcontractor License No.	DIR Registration Number	DBE?
					<input type="checkbox"/> Yes <input type="checkbox"/> No
					<input type="checkbox"/> Yes <input type="checkbox"/> No
					<input type="checkbox"/> Yes <input type="checkbox"/> No
					<input type="checkbox"/> Yes <input type="checkbox"/> No
					<input type="checkbox"/> Yes <input type="checkbox"/> No
					<input type="checkbox"/> Yes <input type="checkbox"/> No
					<input type="checkbox"/> Yes <input type="checkbox"/> No
					<input type="checkbox"/> Yes <input type="checkbox"/> No

(Bidder to attach additional sheets if necessary)

## STATEMENT OF QUALIFICATIONS INSTRUCTIONS

### ARTICLE 1 – GENERAL INFORMATION

#### 1.01 Minimum Bidder Qualifications

- A. Bidders must be duly licensed, pursuant to the license requirements in Notice Inviting Bids, Paragraph 2.01, and in accordance with the California Business & Professions Code §§7006, *et seq.*, and have a history of work performance sufficient to meet the requirements of a responsible bidder in the Public Contract Code Section 1103.
- B. Bidders must have three (3) years' experience as a continuously operating entity engaged in the performance of similar work.

#### 1.02 Measurement

- A. Bidder's compliance with the minimum qualification requirements will be measured by Bidder's experience as an operating entity and also by the experience of the supervisory personnel who will have responsible charge of the various major components of the Work.
- B. If Bidder subcontracts portions of the Work, City, in its determination of whether the minimum qualification requirements have been met, may consider the qualifications of the Subcontractor's supervisory personnel.
- C. The qualifications of the Key Personnel are to be submitted with the Statement of Qualifications (SOQ), by providing the information described herein.

#### 1.03 Other Requirements

- A. Bidder's attention is called to the following minimum requirements for a Bidder to be found responsible to perform the Work:
  1. Building Capacity. Ability to secure, in accordance with the Contract documents, the required forms of Construction Performance Bond and Construction Labor and Material Payment Bond. Ability to obtain required insurance with coverage values that meet minimum requirements.
  2. Subcontracting Prior Experience. Satisfactory experience on public works, including without limitation, no history of default termination, excessively delayed completion or excessive defective work.
  3. Projects Public Experience. Evidence that Bidder and its team, including without limitation its Subcontractors (hereafter, including Bidder if Bidder performs such Work itself, "designated Subcontractor(s)"), have the human and physical resources of sufficient quantity and quality to perform the Work under Contract documents in a timely and Specification-compliant manner, to include:
    - a. Construction and management organizations with sufficient personnel and requisite disciplines, licenses, skills, experience, and equipment for the Project.
    - b. Minimum licensing requirements including evidence of a valid California contractor's license for the Bidder and evidence of requisite licenses for Key Personnel of Bidder or any designated Subcontractor(s).
    - c. Sufficiency of proposed quality assurance plan to meet the requirements of the Contract documents.
    - d. Bidder's safety record.
    - e. A field organization with skills, experience, and equipment sufficient to perform all on-Site work and necessary scheduling.
    - f. Expertise of Key Personnel to accomplish the duties and responsibilities required to perform the Work under Contract documents. Minimum experience requirements of Key Personnel including the completion of three projects of similar nature and complexity and having two years of experience on projects of similar nature and complexity.
    - g. Bidder shall expressly indicate which, if any, of the foregoing designated Subcontractor(s)' functions it will perform itself.

### ARTICLE 2 – REQUIRED CONTENTS OF SOQ SUBMISSION

#### 2.01 Transmittal Letter

- A. The Transmittal Letter shall name the proposed prime contractor, its legal structure (i.e., corporation, partnership, limited partnership, joint venture). If a joint venture or partnership is proposed, Bidder shall identify partner and/or member of the joint venture and their roles and

responsibilities.

**2.02 Submittals**

- A. Completed Questionnaires. Bidder shall include a completed Statement of Qualification Questionnaire in the following form. If any Subcontractors (**Designated Subcontractors Trade(s)**) are identified below, Bidder must include Part D (Experience of Designated Subcontractor) to the Statement of Qualification Questionnaire for each Designated Subcontractor:
  - 1. Designated Subcontractor Trade 1: \_\_\_\_\_
  - 2. Designated Subcontractor Trade 2: \_\_\_\_\_
- B. Surety Letter re: Capability to Provide Required Performance and Payment Bonds. Bidder shall include a letter from a surety duly licensed to do business in the State of California, having a financial rating from A.M. Best Company of [**A-, VIII or A-, V**] or better, that the surety has agreed to provide Bidder with the required performance and payment bonds in accordance with the requirements set forth in the Construction Performance Bond and Construction Labor and Material Payment Bond documents, each in the penal sum of the Contractor's bid when submitted. City shall have the right to verify with the surety that the surety, based upon the Bid prices, will issue the required bonds under the conditions stated.
- C. Insurer Letter re: Capability to Provide the Required Insurance. Bidder shall provide a letter from an insurance underwriter, having a financial rating reasonably acceptable to City, confirming that the insurer will provide Bidder the required coverages and amounts specified in the Contract Documents.
- D. License: Evidence of a valid contractor's license and required licenses of all licensees of persons who are Key Personnel necessary to perform the Work.
- E. Litigation History. Description of litigation history involving the Contractor in a professional capacity for the past three years including names of involved parties, nature of dispute, and disposition.

**2.03 Format**

- A. The SOQ shall be clear and concise to enable management-oriented personnel to make a thorough evaluation and arrive at a sound determination as to whether the SOQ meets City's requirements. To this end, the SOQ should be so specific, detailed and complete as to demonstrate clearly and fully that the Bidder has a thorough understanding of and has demonstrated knowledge of the requirements to perform the Work (or applicable portion thereof).
- B. Any explanation requested by a Bidder regarding the meaning or interpretation of the SOQ must be requested in writing and with sufficient time allowed for a reply to reach Bidder before the submission of its SOQ. Oral explanations or instructions will not be binding. Any information provided to any prospective Bidder concerning this SOQ document will be furnished to all prospective Bidders as an Addendum to the Bidding Documents.

**[NEXT PAGE - STATEMENT OF QUALIFICATIONS QUESTIONNAIRE]**

**STATEMENT OF QUALIFICATIONS QUESTIONNAIRE**

Bidders shall complete the entire Statement of Qualifications Questionnaire and submit it in accordance with the Instructions to Bidders and Statement of Qualifications Instructions. Failure to complete the questionnaire or inclusion of any false statement(s) shall be ground for immediate disqualification.

**CONTACT INFORMATION**

Company Name: \_\_\_\_\_

City of Company: \_\_\_\_\_

Contact Person: \_\_\_\_\_

Address: \_\_\_\_\_

Phone: \_\_\_\_\_ Fax: \_\_\_\_\_

Email: \_\_\_\_\_

**PART A: GENERAL INFORMATION**

1. Does Bidder possess a valid and current California Contractor's license for the work proposed?	Yes ___ No ___
2. Does Bidder have the minimum liability insurance coverage required in the Insurance and Indemnification document?	Yes ___ No ___
3. Has Bidder's Contractor's License been revoked at any time within the last five years?	Yes ___ No ___
4. Has Bidder been "default terminated" by any City (other than for convenience), or has a Surety completed a contract for Bidder within the last five years?	Yes ___ No ___
5. Has Bidder been convicted more than twice for failure to pay prevailing wages in the last three years?	Yes ___ No ___
6. Are Bidder and all listed subcontractors registered and qualified with the Department of Industrial Relations pursuant to Labor Code Section 1725.5?	Yes ___ No ___

**Bidder may be disqualified if any answer to questions 1, 2, or 6 is No.  
Bidder may be disqualified if any answer to questions 3, 4, or 5 is Yes.**

**PART B: SAFETY, PREVAILING WAGE, DISPUTES AND BONDS**

**(SAFETY)**

Has Cal/OHSA, Federal OSHA, the EPA or any Air Quality Management Agency cited Bidder in the past five years? If yes, attach description of each citation.

Yes \_\_\_\_\_ No \_\_\_\_\_



**(PREVAILING WAGE PROVISIONS)**

Has Bidder been fined, penalized or otherwise found to have violated any prevailing wage or labor code provision? If yes, attach description of each occurrence.

Yes \_\_\_\_\_ No \_\_\_\_\_

**(LICENSE PROVISIONS)**

Has Bidder changed names or license numbers in the past five years? If so, please state reason for change.

Yes \_\_\_\_\_ No \_\_\_\_\_ Reason: \_\_\_\_\_  
\_\_\_\_\_

**(DISPUTES)**

In the past five years, has Bidder on any project that Bidder performed construction services made any written claim against any City for additional compensation or additional time, that the City disputed, exceeding on a per project basis an aggregate amount of \$100,000 or 10% of the original contract sum? If yes, attach description of each instance including details of total claim(s) amount, resolution description including amount, and City's name and phone number.

Yes \_\_\_\_\_ No \_\_\_\_\_

In the past five years, has any City on any project that Bidder performed construction services asserted any written claim against Bidder for delay, defective work, warranty work, back charges and/or offsets, that the Bidder disputed, exceeding on a per project basis, an aggregate amount of \$100,000 or 10% of the original contract sum? If yes, attach description of each instance including details of total claim(s) amount, resolution description including amount, and City's name and phone number.

Yes \_\_\_\_\_ No \_\_\_\_\_

**(BONDING)**

Bonding Capacity – Provide documentation from Bidder's surety identifying the following:

Name of bonding company/surety: \_\_\_\_\_

Name of Surety Agent: \_\_\_\_\_

Surety Agent address: \_\_\_\_\_

Surety Agent phone number: \_\_\_\_\_

Is surety a California-admitted surety? Yes \_\_\_\_\_ No \_\_\_\_\_

Is surety listed in the current edition of the California Department of the Treasury's Listing of approved sureties? Yes \_\_\_\_\_ No \_\_\_\_\_

List surety's A.M. Best Rating: \_\_\_\_\_

What is Bidder's total bonding capacity? \_\_\_\_\_

What percent does Bidder pay for bonds? \_\_\_\_\_

**PART C: EXPERIENCE OF PRIME CONTRACTOR**

The nature of this Project requires prior similar experience for the firm and the Key Personnel assigned. Summarize similar project experience below and provide the detailed project information requested:

**Prime Contractor**

List three (3) projects of similar size and scope to the Work of the Contract, completed in the past, and indicate who were the superintendent, project manager and scheduler. NOTE: This listing will be used to assess compliance with the stated minimum qualifications in Paragraph 2.01 of the Notice Inviting Bids.

Project Name/Description	Construction Cost (\$)	Address	Contact Person & Phone Number

**Key Personnel**

List Key Personnel that will be assigned to the Work of the current Project and their experience/training with the projects listed above:

Project Manager: \_\_\_\_\_

Project Superintendent: \_\_\_\_\_

Project Scheduler: \_\_\_\_\_

**Recent Projects**

Provide information about three (3) of Bidder's most currently completed projects. Names and references must be current and verifiable. NOTE: This listing will be used to assess compliance with the stated minimum qualifications in Paragraph 1.01 of the Instructions. If a separate sheet is used, it must contain all of the following information:

1. Project Name: \_\_\_\_\_

Location: \_\_\_\_\_

City: \_\_\_\_\_

City Contact (name and phone): \_\_\_\_\_

Architect/Engineer: \_\_\_\_\_

Architect/Engineer Contact (name and phone number): \_\_\_\_\_

Const. Mgr. or Project Mgr. (name and phone number): \_\_\_\_\_

Description of Project, Scope of Work Performed: \_\_\_\_\_

\_\_\_\_\_

Total Construction Cost: \_\_\_\_\_

Total Change Order Amount: \_\_\_\_\_

Did Change Orders exceed 10% of original contract sum? \_\_\_\_\_ If yes, please explain on separate sheet.

Original Scheduled Date of Completion: \_\_\_\_\_

Time Extensions Granted (number of Days): \_\_\_\_\_

Actual Date of Completion: \_\_\_\_\_

Number of Stop Notices filed by Subcontractors or Suppliers: \_\_\_\_\_

2. Project Name: \_\_\_\_\_

Location: \_\_\_\_\_

City: \_\_\_\_\_

City Contact (name and phone): \_\_\_\_\_

Architect/Engineer: \_\_\_\_\_

Architect/Engineer Contact (name and phone number): \_\_\_\_\_

Const. Mgr. or Project Mgr. (name and phone number): \_\_\_\_\_

Description of Project, Scope of Work Performed: \_\_\_\_\_

\_\_\_\_\_

Total Construction Cost: \_\_\_\_\_

Total Change Order Amount: \_\_\_\_\_

Did Change Orders exceed 10% of original contract sum? \_\_\_\_\_ If yes, please explain on separate sheet.

Original Scheduled Date of Completion: \_\_\_\_\_

Time Extensions Granted (number of Days): \_\_\_\_\_

Actual Date of Completion: \_\_\_\_\_

Number of Stop Notices filed by Subcontractors or Suppliers: \_\_\_\_\_

3. Project Name: \_\_\_\_\_

Location: \_\_\_\_\_

City: \_\_\_\_\_

City Contact (name and phone): \_\_\_\_\_

Architect/Engineer: \_\_\_\_\_

Architect/Engineer Contact (name and phone number): \_\_\_\_\_

Const. Mgr. or Project Mgr. (name and phone number): \_\_\_\_\_

Description of Project, Scope of Work Performed: \_\_\_\_\_

\_\_\_\_\_

Total Construction Cost: \_\_\_\_\_

Total Change Order Amount: \_\_\_\_\_

Did Change Orders exceed 10% of original contract sum? \_\_\_\_\_ If yes, please explain on separate sheet.

Original Scheduled Date of Completion: \_\_\_\_\_

Time Extensions Granted (number of Days): \_\_\_\_\_

Actual Date of Completion: \_\_\_\_\_

Number of Stop Notices filed by Subcontractors or Suppliers: \_\_\_\_\_

**PART D: EXPERIENCE OF DESIGNATED SUBCONTRACTOR**  
*[See Paragraph 2.02.A of Notice Inviting Bids]*

**General Contractor Name:** \_\_\_\_\_

**Designated Subcontractor Name:** \_\_\_\_\_

The nature of this Project requires prior similar experience for the Designated Subcontractor Trade(s) performing the Work. Summarize similar project experience below and provide the detailed project information requested:

**Designated Subcontractor.** List three (3) projects of similar size and scope to the Work of the Contract, completed in the past, and indicate who were the superintendent, project manager and scheduler. **NOTE:** This listing will be used to assess compliance with the stated minimum qualifications in Paragraph 1.01 of the Instructions for this form.

Project Name/Description	Construction Cost (\$)	Address	Contact Person & Phone Number

**Key Personnel.**

List Key Personnel that will be assigned to the Work of the current Project and their experience/training with the projects listed above:

Project Manager: \_\_\_\_\_

**PART E: FINANCIAL INFORMATION**

- 1. Has Bidder ever reorganized under the protection of bankruptcy laws?  
Yes \_\_\_\_\_ No \_\_\_\_\_ If yes, please state when \_\_\_\_\_
- 2. If Bidder has had the general liability carrier identified in the Bidder Registration and Safety Experience Form for less than five years, please provide additional information below for balance of the last five years:

Agency Name: \_\_\_\_\_

Contact Name: \_\_\_\_\_

Phone Number \_\_\_\_\_

Carrier: \_\_\_\_\_ A.M. Best Rating: \_\_\_\_\_

Carrier: \_\_\_\_\_ A.M. Best Rating: \_\_\_\_\_

Carrier: \_\_\_\_\_ A.M. Best Rating: \_\_\_\_\_

- 3. Has Bidder ever had insurance terminated by a carrier? Yes \_\_\_\_\_ No \_\_\_\_\_  
If yes, explain on a separate signed sheet marked with correlating cross-reference to this paragraph of the questionnaire.

Bidder hereby declares under penalty of perjury that all the information provided in this questionnaire is true and correct.

\_\_\_\_\_  
SIGNATURE

\_\_\_\_\_  
TITLE

PUBLIC CONTRACT CODE §7106

NON-COLLUSION AFFIDAVIT TO BE EXECUTED BY BIDDER AND SUBMITTED WITH BID

STATE OF CALIFORNIA )  
 ) ss.  
COUNTY OF \_\_\_\_\_ )

\_\_\_\_\_, being first duly sworn,  
(Name of Principal of Bidder)

deposes and says that he or she is the \_\_\_\_\_  
(Office or Title of Affiant)

of \_\_\_\_\_, the party  
(Name of Bidder)

making the foregoing Bid, that the Bid is not made in the interest of, or on behalf of, any undisclosed person, partnership, company, association, organization, or corporation; that the Bid is genuine and not collusive or sham; that Bidder has not directly or indirectly induced or solicited any other bidder to put in a false or sham Bid, and has not directly or indirectly colluded, conspired, connived or agreed with any bidder or anyone else to put in a sham Bid, or that anyone shall refrain from bidding, and that the Bidder has not in any manner, directly or indirectly, sought by agreement, communication or conference with anyone to fix the Bid price of Bidder or any other bidder, or to fix any overhead, profit or cost element of the Bid price, or of that of any other bidder, or to secure any advantage against City, or anyone interested in the proposed contract; that all statements contained in the Bid are true; and further, that Bidder has not, directly or indirectly, submitted its Bid price or any breakdown thereof, or the contents thereof, or divulged information or data relative thereto, or paid, and will not pay, any fee to any corporation, partnership, company, association, organization, Bid depository, or to any member or agent thereof to effectuate a collusive or sham Bid.

Executed under penalty of perjury under the laws of the State of California:

\_\_\_\_\_  
(Name of Bidder)

\_\_\_\_\_  
(Signature of Principal)

A notary public or other officer completing this certificate verifies only the identity of the individual who signed the document to which this certificate is attached, and not the truthfulness, accuracy, or validity of that document.

State of California )  
 ) ss.  
County of \_\_\_\_\_ )

Subscribed and sworn to (or affirmed) before me this \_\_\_\_\_ day of \_\_\_\_\_, 20\_\_

by \_\_\_\_\_  
proved to me on the basis of satisfactory evidence to be the person(s) who appeared before me.

(Seal)

\_\_\_\_\_  
Signature of Notary Public

**NOTE:** If Bidder is a partnership or a joint venture, this affidavit must be signed and sworn to by every member of the partnership or venture.

**NOTE:** If Bidder [including any partner or venturer of a partnership or joint venture] is a corporation, this affidavit must be signed by the Chairman, President, or Vice President and by the Secretary, Assistant Secretary, Chief Financial Officer, or Assistant Treasurer.

**NOTE:** If Bidder's affidavit on this form is made outside the State of California, the official position of the person taking such affidavit shall be certified according to law.



**BIDDER CERTIFICATIONS**  
TO BE EXECUTED BY ALL BIDDERS AND SUBMITTED WITH BID

The undersigned Bidder certifies to City as set forth in Articles 1 through 8 below:

**ARTICLE 1 – STATEMENT OF CONVICTIONS**

By my signature hereunder, I hereby swear, under penalty of perjury, that no more than one final, unappealable finding of contempt of court by a Federal Court has been issued against Bidder within the past two years because of failure to comply with an order of a Federal Court or to comply with an order of the National Labor Relations Board.

**ARTICLE 2 - CERTIFICATION OF WORKER’S COMPENSATION INSURANCE**

By my signature hereunder, as the Contractor, I certify that I am aware of the Labor Code Section 3700, which requires every employer to be insured against liability for worker's compensation or to undertake self-insurance in accordance with the provisions of that Code, and I will comply with such provisions before commencing the performance of the work of this Contract.

**ARTICLE 3 - CERTIFICATION OF PREVAILING WAGE RATES AND RECORDS**

By my signature hereunder, as the Contractor, I certify that I am aware of Labor Code Section 1773, which requires the payment of prevailing wage on public projects. Contractor and any subcontractors under the Contractor shall comply with Labor Code Section 1776 regarding wage records, and with Labor Code Section 1777.5 regarding the employment and training of apprentices. Contractor is responsible to ensure compliance by any and all subcontractors performing work under this Contract.

**ARTICLE 4 - CERTIFICATION OF COMPLIANCE WITH PUBLIC WORKS CHAPTER OF LABOR CODE**

By my signature hereunder, as the Contractor, I certify that I am aware of Labor Code Sections 1777.1 and 1777.7 Code, and Contractor and Subcontractors are eligible to bid and work on public works projects.

**ARTICLE 5 - CERTIFICATION OF NON-DISCRIMINATION**

By my signature hereunder, as the Contractor, I certify that there will be no discrimination in employment with regard to race, color, religion, gender, sexual orientation, age or national origin; that all federal, state, and local directives and executive orders regarding non-discrimination in employment will be complied with; and that the principal of equal opportunity in employment will be demonstrated positively and aggressively.

**ARTICLE 6 - CERTIFICATION OF NON-DISQUALIFICATION**

By my signature hereunder, as the Contractor, I swear, under penalty of perjury, that the below indicated Bidder, any officer of Bidder, or any employee of Bidder who has a proprietary interest in such Bidder, has never been disqualified, removed, or otherwise prevented from bidding on, or completing a Federal, State, or local government project because of a violation of law or safety regulation, except as indicated on the separate sheet attached hereto entitled “Previous Disqualifications.” If a statement of “Previous Disqualifications” is attached, please explain the circumstances.

**ARTICLE 7 - CERTIFICATION OF ADEQUACY OF CONTRACT AMOUNT**

By my signature hereunder, as the Contractor, pursuant to Labor Code Section 2810(a), I certify that, if awarded the Contract based on the undersigned’s Bid, the Contract will include funds sufficient to allow the Contractor to comply with all applicable local, state, and federal laws or regulations governing the labor or services to be provided. I understand that City will be relying on this certification if it awards the Contract to the undersigned.

**ARTICLE 8 - CERTIFICATION REGARDING DIR CONTRACTOR / SUBCONTRACTOR REGISTRATION**

By my signature hereunder, as the Contractor, I certify that Contractor, and all Subcontractors listed on the Subcontractors List are the subject of current and active contractor registrations pursuant to Division 2, Part 7, Chapter 1 (commencing with section 1720) of the California Labor Code. Contractor’s registration number is \_\_\_\_\_ **[please complete]**. Subcontractors’ registration numbers are as indicated in the Subcontractors List.

**BIDDER:**

\_\_\_\_\_ (Name of Bidder)

Date: \_\_\_\_\_

By: \_\_\_\_\_  
(Signature)

Name: \_\_\_\_\_  
(Print Name)

Its: \_\_\_\_\_  
(Title)

**SUBSTITUTION REQUEST FORM**

To: **CITY OF FORT BRAGG**

<b>PROJECT:</b>	<b>Contractor:</b>
<b>City Project No:</b>	

Substitution Request By:	Firm:
--------------------------	-------

Transmittal Record	Attn:	Firm:	Date Sent:	Date Rec'd:	Date Due:
Contractor to City					
Contractor to Architect					
City / Architect to Consultant					
Architect to City Representative					
City Representative to Contractor					

We hereby submit for your consideration the following product instead of the specified item for the Project:

Section / Drawing	Article	Specified Item
<b>Proposed Substitution:</b>		

We have (a) attached manufacturer's literature, including complete technical data and laboratory test results, if applicable, (b) attached an explanation of why proposed substitution is a true equivalent to specified item, (c) included complete information on changes to Contract Documents that the proposed substitution will require for its proper installation, and (d) filled in the blanks below:

**Contractor to complete the questions that follow and certify to the accuracy of all answers:**

A.	Does the substitution affect dimensions shown on Drawings? Yes ___ / No ___. If No, please explain proposed mitigation and why substitution is equivalent to originally specified item:
B.	Will the undersigned pay for changes to the building design, including engineering and detailing costs caused by the requested substitution? Yes ___ / No ___. If No, please state reasons explaining why substitution is equivalent to originally specified item:
C.	What effect does the substitution have on other trades? No effect: ___ / Some effect ___. If substitution will affect other trades, please explain the effect and why substitution is equivalent to originally specified item:
D.	Will substitution cause change to Project Schedule, or to critical delivery dates? Add? Shorten? If the substitution will add to schedule dates or affect critical activities, please explain why substitution is equivalent to originally specified item:
E.	Please describe differences between proposed substitution and specified item. Please explain and identify any and all differences, and please explain why substitution is equivalent to originally specified item:
F.	What is the Cost Differential to Contractor in original specified item and proposed substitution including all mark-ups? [If substitution requested during bid period, skip this question.]
G.	Are Manufacturer's guarantees for the proposed item the same as for item specified? Yes ____; No _____. If No, please explain why substitution is equivalent to originally specified item:

H.	Does Contractor accept full responsibility for delays caused by redesign of other items of the Work necessitated by substitution? Yes ___ / No ___. If No, please state reasons and explain why substitution is equivalent to originally specified item:
I.	Does Contractor state that the function, appearance and quality are equivalent or superior to the specified item? Yes ___ / No ___. If No, please explain why substitution is equivalent to originally specified item:

We certify that the function, appearance, and quality of the proposed substitution are equivalent or superior to those of the specified item, except as we may specifically state otherwise in this request.

Submitted by: \_\_\_\_\_ Signature: \_\_\_\_\_

Firm: \_\_\_\_\_ Date: \_\_\_\_\_

Address: \_\_\_\_\_ Phone/ Fax: \_\_\_\_\_

Remarks: \_\_\_\_\_

<p><b>Consultant Response:</b></p> <p><input type="radio"/> Accepted</p> <p><input type="radio"/> Not Accepted</p> <p><input type="radio"/> Accepted As Noted</p> <p><input type="radio"/> Received Too Late</p>
--

<p><b>City Representative Response:</b></p> <p><input type="radio"/> Accepted</p> <p><input type="radio"/> Not Accepted</p> <p><input type="radio"/> Accepted As Noted</p> <p><input type="radio"/> Received Too Late</p>
---

Remarks: \_\_\_\_\_

Remarks: \_\_\_\_\_

\_\_\_\_\_

\_\_\_\_\_

By: \_\_\_\_\_

By: \_\_\_\_\_

**SUPPLEMENTAL GENERAL CONDITIONS**

**[OPTIONAL]**

**SUPPLEMENTARY CONDITIONS – HAZARDOUS MATERIALS**

**[OPTIONAL]**

## SUMMARY

### PART 1 - GENERAL

#### 1.01 Work Covered by Contract Documents

- A. The Work of this Contract comprises construction of all the Work indicated, described in the Specifications, or otherwise required by the Contract Documents. Unless provided otherwise in the Contract Documents, all risk of loss to Work covered by Contract Documents shall rest with Contractor until Final Acceptance of the Work. Cost of maintenance of systems and equipment prior to Final Acceptance will be considered as included in prices Bid and no direct or additional payment will be made therefore.
- B. For all Bid items, furnish and install all Work, including connections to existing systems, indicated and described in Specifications and all other Contract Documents. Work and requirements applicable to each individual Bid item, or unit of Work, shall be deemed incorporated into the description of each Bid item (whether Lump Sum or Unit Price). Any Bid item may be deleted from the Work and Contract Sum, in total or in part, prior to or after award of Contract without compensation in any form or adjustment of other Bid items or prices therefore.
- C. Allowance Work shall be done as Change Orders and as specified in the Modification Procedures section of this Document. Identify Allowance Items (from Bid Form) on the Progress Schedules and on Applications for Payment. The Amount given on the Bid Form under each Allowance Item is the sum of money set aside for each Allowance Item. These amounts shall be included in the Contract Sum on the Bid Form. If the cost of Work done under any Allowance Item is less than the amount given on the Bid Form under that Allowance Item, the Contract Sum shall be reduced by the difference between the amount given in the Bid Form and the cost of Work actually done.

#### 1.02 Work Sequence

- A. Construct Work in stages and at times to accommodate City operation requirements during the construction period; coordinate construction schedule and operations with City.

#### 1.03 Cooperation of Contractor and Coordination with Other Work

- A. Coordinate with City and any City forces, or other contractors and forces, as required by the General Conditions.

#### 1.04 Partial Occupancy/Utilization Requirements

- A. Allow City to take possession of and use any completed or partially completed portion of the Work during the progress of the Work as soon as is possible without interference to the Work.
- B. Possession, use of Work, and placement and installation of equipment by City shall not in any way evidence the completion of the Work or any part of it.
- C. Contractor shall not be held responsible for damage to the occupied part of the Work resulting from City occupancy.
- D. Make available, in areas occupied, on a 24 hour per day and 7 day per week basis if required, any utility services, heating, and cooling in condition to be put in operation at the time of occupancy.
  - 1. Responsibility for operation and maintenance of said equipment shall remain with Contractor.
  - 2. Make, and City shall certify, an itemized list of each piece of equipment so operated with the date operation commences.
  - 3. Itemized list noted above shall be basis for commencement of warranty period for equipment.
  - 4. City shall pay for utility cost arising out of occupancy by City during construction.
- E. Use and occupancy by City prior to acceptance of Work does not relieve Contractor of its responsibility to maintain insurance and bonds required under the Contract until entire Work is completed and accepted by City.
- F. Prior to date of Final Acceptance of the Work by City, all necessary repairs or renewals in Work or part thereof so used, not due to ordinary wear and tear, but due to Defective materials or workmanship or to operations of Contractor, shall be made at expense of Contractor, as required in the General Conditions.
- G. Use by City of Work or part thereof as contemplated by this Section of the General Requirements shall in no case be construed as constituting acceptance of Work or any part thereof. Such use



shall neither relieve Contractor of any responsibilities under Contract, nor act as waiver by City of any of the conditions thereof.

**1.05** ***[SECTION REMOVED]***





# VOLUME 2



**Bollard & Street Light  
Project  
PWP-00127**



CITY OF FORT BRAGG  
416 N. Franklin Street  
Fort Bragg, California 95437

**CONTRACT CHECK LIST**

Complete, accurate, executed copies of the following documents must be submitted to the CITY OF FORT BRAGG in accordance with the bid package issued by the City for the **Bollards & Street Light Project, Project No. PWP-00127**, within ten (10) working days of receiving written notice of award of the project. The bidder's security of any successful bidder that fails to do so will be forfeited to the City.

\_\_\_\_\_ Contract Check List

\_\_\_\_\_ Contract, Part 1

\_\_\_\_\_ Contract, Part 2 – General Provisions

\_\_\_\_\_ Contract, Part 3 – Special Provisions

\_\_\_\_\_ Performance Bond

\_\_\_\_\_ Payment Bond

\_\_\_\_\_ Maintenance Bond

\_\_\_\_\_ Certificates of Insurance and Endorsements

\_\_\_\_\_ Escrow Agreement for Security Deposit (if applicable)

City of Fort Bragg  
Project No. PWP-00127  
Contract, Part 1

***\*\*\*THIS PAGE INTENTIONALLY LEFT BLANK\*\*\****

CITY OF FORT BRAGG  
416 Franklin Street  
Fort Bragg, California 95437

### CONTRACT, PART 1

The CITY OF FORT BRAGG, 416 N. Franklin Street, Fort Bragg, California 95437 (“City”) enters into this Contract, dated [REDACTED], for reference purposes only, with [Name and Address of Contractor] (“Contractor”).

#### RECITALS

- A. NOTICE INVITING BIDS. The City gave notice inviting bids to be submitted by **Friday, December 2, 2022 for the Bollard & Street Lights Project** (“Project”) by published notice and/or posting in accordance with California Public Contract Code Section 20164 and other applicable law.
- B. BID OPENING. On Friday, December 2, 2022, City representatives opened the bids for the Project and read the bids aloud.
- C. PROJECT AWARD. On December 12, 2022 the City Council awarded the Project to the Contractor and directed City staff to send the Contractor written notice of award of the project. The City Council conditioned award of the project on the Contractor’s providing executed copies of all documents specified in the contract check list included in the bid package within ten (10) working days of receiving written notice of award of the project.
- D. REQUIRED DOCUMENTS. The Contractor has provided the City executed copies of all documents specified in the contract check list included in the bid package within ten (10) working days of receiving written notice of award.
- E. INVESTIGATION AND VERIFICATION OF SITE CONDITIONS. The Contractor warrants that it has conducted all necessary pre-bid investigations and other obligations, and agrees that it shall not be entitled to Change Orders (time or compensation) due to any information, error, inconsistency, omission, or conditions that Contractor should have known as a part of this Work. Contractor shall be responsible for the resultant losses, including, without limitation, the cost of correcting Defective Work. In executing this Contract, Contractor shall rely on the results of its own independent investigation and shall not rely on City-supplied information regarding above ground conditions and as-built conditions, and Contractor shall accept full responsibility for its verification work sufficient to complete the Work as intended.

#### CONTRACT TERMS

The City and the Contractor agree as follows:

- 1. THE WORK. The Contractor shall furnish all equipment, tools, apparatus, facilities, material labor, and skill necessary to perform and complete in a good and workmanlike manner the **Bollard and Streetlights Project** (“Work”) as shown in the Technical

City of Fort Bragg  
Project No. PWP-00127  
Contract, Part 1





and income taxes, customs, duties, and any and all other taxes on any item or service that is part of the Work, whether such taxes are normally included in the price of such item or service or are normally stated separately. Notwithstanding the foregoing, each party shall bear such state or local inventory, real property, personal property or fixtures taxes as may be properly assessed against it by applicable taxing authorities.

6. PREVAILING WAGES. In accordance with California Labor Code Section 1771, not less than the general prevailing rate of per diem wages for work of a similar character in the locality in which the Work is to be performed, and not less than the general prevailing rate of per diem wages for holiday and overtime work fixed as provided in the California Labor Code must be paid to all workers engaged in performing the Work. In accordance with California Labor Code Section 1770 et seq., the Director of Industrial Relations has determined the general prevailing wage per diem rates for the locality in which the Work is to be performed. In accordance with California Labor Code Section 1773, the City has obtained the general prevailing rate of per diem wages and the general rate for holiday and overtime work in the locality in which the Work is to be performed for each craft, classification or type of worker needed to perform the project. In accordance with California Labor Code Section 1773.2, copies of the prevailing rate of per diem wages are on file at the City Public Works Department and will be made available on request. Throughout the performance of the Work the Contractor must comply with all provisions of the Contract Documents and all applicable laws and regulations that apply to wages earned in performance of the Work.

6.1. Contractor acknowledges and agrees that it shall comply with the requirements of California Public Contracts Code sections 2600 et seq., in its entirety and, in particular, those sections related to Skilled and Trained Workforce. By its execution of this agreement Contractor certifies and warrants that it is aware of the requirement of California Public Contracts Code section 2600 et seq. and its requirements as to a Skilled and Trained Workforce.

7. THE CONTRACT DOCUMENTS. This Contract consists of the following documents ("Contract Documents"), all of which are incorporated into and made a part of this Contract as if set forth in full. In the event of a conflict between or among the Contract Documents, precedence will be in the following order:

- 7.1 This Part 1 of the Contract and change orders and other amendments to this Contract signed by authorized representatives of the City and the Contractor.
- 7.2 The General Provisions, Part 2 of the Contract, and change orders and other amendments to the General Provisions signed by authorized representatives of the City and the Contractor.
- 7.3 The Special Provisions, Part 3 of the Contract, addenda to the Special Provisions signed by authorized representatives of the City and issued prior to bid opening, Equal Product Proposals accepted by the City and signed by authorized representatives prior to bid opening, and change orders and other amendments

to the Special Provisions signed by authorized representatives of the City and the Contractor.

- 7.4 The Technical Specifications, addenda to the Technical Specifications signed by authorized representatives of the City and issued prior to bid opening, Equal Product Proposals accepted by the City and signed by authorized City representatives prior to bid opening, and change orders and other amendments to the Technical Specifications signed by authorized representatives of the City and the Contractor.
- 7.5 The Project Plans, addenda to the Project Plans signed by authorized representatives of the City and issued prior to bid opening, Equal Product Proposals accepted by the City and signed by authorized City representatives prior to bid opening, and change orders and other amendments to the Project Plans signed by authorized representatives of the City and the Contractor.
- 7.6 Notice Inviting Bids
- 7.7 Instructions to Bidders
- 7.8 The successful bidder's completed Proposal Cover Page and Bid Schedule
- 7.9 The successful bidder's completed Contractor License Information
- 7.10 The successful bidder's completed List of Proposed Subcontractors
- 7.11 The successful bidder's Workers Compensation Insurance Certification
- 7.12 The successful bidder's completed Non-collusion Affidavit
- 7.13 The successful bidder's Debarment Certification
- 7.14 The successful bidder's completed Certificates of Insurance and Endorsements
- 7.15 The successful bidder's executed Performance Bond
- 7.16 The successful bidder's executed Payment Bond
- 7.17 The Maintenance Bond form included in the bid package that the Contractor must execute prior to release of final payment under the Contract
- 7.18 The successful bidder's Qualification Statement, if any
- 7.19 The successful bidder's signed Signature Form

8. PROVISIONS INCORPORATED BY REFERENCE. Provisions or parts of provisions that are incorporated by reference and not set forth at length in any of the Contract Documents will only form a part of this Contract to the extent the Contract Documents expressly make such provisions or parts of provisions a part of this Contract. For example, published public works agreement provisions, such as those of the State of California Department of Transportation Standard Specifications (known as the Standard Specifications) are only a part of this Contract to the extent expressly incorporated in the Contract by section number. When such published provisions are made a part of this Contract, references in the published provisions to other entities,

such as the State, the Agency, or similar references, will be deemed references to the City as the context of this Contract may require.

9. INTERPRETATION OF CONTRACT DOCUMENTS. Any question concerning the intent or meaning of any provision of the Contract Documents, including, but not limited to, the Technical Specifications or Project Plans, must be submitted to the Public Works Director, or his/her designee, for issuance of an interpretation and/or decision by the authorized Public Works Director in accordance with the requirements of the Contract Documents. Interpretations or decisions by any other person concerning the Contract Documents will not be binding on the City. The decision of the Public Works Director, or his/her designee, shall be final.
10. ASSIGNMENT PROHIBITED. The Contractor may not assign part or all of this Contract, or any monies due or to become due under this Contract, or any other right or interest of the Contractor under this Contract, or delegate any obligation or duty of the Contractor under this Contract without the prior written approval of an official authorized to bind the City and an authorized representative of Contractor's surety or sureties. Any such purported assignment or delegation without such written approval on behalf of the City and the Contractor's sureties will be void and a material breach of this Contract subject to all available remedies under this Contract and at law and equity.
11. CONTRACTOR'S LICENSE CERTIFICATION. By signing this Contract the Contractor certifies that the Contractor holds a valid Type **A, or B, or a Class C if they hold all of the following: C-10, C-12, and C-33 contractor license** issued by the California State Contractors Licensing Board, and that the Contractor understands that failure to maintain its license in good standing throughout the performance of the Work may result in discipline and/or other penalties pursuant to the California Business and Professions Code, and may constitute a material breach of this Contract subject to all available remedies under this Contract and at law and equity.
12. SEVERABILITY. If any term or provision or portion of a term or provision of this Contract is declared invalid or unenforceable by any court of lawful jurisdiction, then the remaining terms and provisions or portions of terms or provisions will not be affected thereby and will remain in full force and effect.
13. PROJECT REPRESENTATIVES
  - 13.1 The City has designated **Chantell O'Neal** as its Project Manager to act as its Representative in all matters relating to the Contract. If Project Manager is an employee of City, Project Manager is the beneficiary of all Contractor obligations to the City including, without limitation, all releases and indemnities.

Project Manager shall have final authority over all matters pertaining to the Contract and shall have sole authority to modify the Contract on behalf of the City, to accept work, and to make decisions or actions binding on the City, and shall have sole signature authority on behalf of the City.

The City may assign all or part of the Project Manager's rights, responsibilities and duties to a construction manager or other City representative.

13.2 The Contractor has designated [REDACTED] as its Project Manager to act as Contractor's Representative in all matters relating to the Contract. The Contractor's Project Manager shall have final authority over all matters pertaining to the Contract and shall have sole authority to modify the Contract on behalf of the Contractor and to make decisions or actions binding on the Contractor, and shall have sole signature authority on behalf of the Contractor.

**SIGNATURES ON FOLLOWING PAGE**

Executed on \_\_\_\_\_, 20\_\_ by

CONTRACTOR

CITY

By: \_\_\_\_\_  
Title: \_\_\_\_\_

By: \_\_\_\_\_  
Title: Peggy Ducey  
City Manager

[Attach Notary Acknowledgment Page]

ATTEST:

By: \_\_\_\_\_  
June Lemos, MMC  
City Clerk

APPROVED AS TO FORM:

By: \_\_\_\_\_  
Keith F. Collins  
City Attorney

CITY OF FORT BRAGG  
416 Franklin Street  
Fort Bragg, California 95437

**CONTRACT, PART 2**  
**GENERAL PROVISIONS**

1. DEFINITIONS

The following terms as used in any agreement of which these General Provisions are a part are defined as follows:

- 1.1 **Architect or Engineer:** The person or persons so specified on the title sheet of the Technical Specifications and/or Project Plans.
- 1.2 **ASTM:** American Society for Testing and Materials, latest edition.
- 1.3 **Bid Package:** All of the documents listed as comprising the entire Bid Package as specified in the Instructions to Bidders and representing the full set of documents made available to bidders on the Project.
- 1.4 **Caltrans Standard Specifications:** Caltrans construction manual entitled, "State of California, Department of Transportation, Standard Specifications," latest edition.
- 1.5 **City:** CITY OF FORT BRAGG.
- 1.6 **Construction Manager:** The City's authorized representative for administration and overall management of the Project contract and Work. The Construction Manager is the official point of contact between the City, the Architect and/or Engineer, and the Contractor. The Construction Manager for this project shall be **Assistant Director of Engineering, Chantell O'Neal**.
- 1.7 **Contract:** The agreement between the City and Contractor concerning the Project, as evidenced by and comprised of the Contract Documents.
- 1.8 **Contract Documents:** All documents identified in Section 7 of Part 1 of the Contract.
- 1.9 **Contractor:** The successful bidder for the Project and party to the Project agreement with the City as specified in the Project agreement. **[INCLUDE NAME OF CONTRACTOR]**
- 1.10 **Days:** Unless otherwise specified in the Contract Documents, Days mean working days.
- 1.11 **Project:** The **Bollard and Streetlights Project** as described in the Technical Specifications and Project Plans.
- 1.12 **Project Inspector:** The party or parties charged by the City with inspecting the Work for compliance with the requirements of the Contract Documents and

City of Fort Bragg  
Project No. PWP-00127  
Contract, Part 2  
General Provisions

applicable laws and regulations. The Project Inspector acts under the direction of the City and shall coordinate with the Construction Manager and Architect as directed by the City in accordance with the Contract Documents.

- 1.13 **Project Plans:** The primarily graphic detailed requirements concerning the Project contained in Volume 3 of the Bid Package and any addenda to the Project Plans signed by authorized City representatives and issued prior to bid opening, Equal Product Proposals accepted by the City and signed by authorized City representatives prior to bid opening, and change orders and other amendments to the Project Plans signed by authorized representatives of the City and the Contractor in accordance with the requirements of the Contract Documents.
- 1.14 **Subcontractor:** A person, firm or corporation that is obligated as a party to a contract with the Contractor to perform part of the Project work. For purposes of these General Provisions Subcontractors include, but are not limited to, those that are obligated as parties to a contract with the Contractor to specially fabricate and install a portion of the Project Work according to the Technical Specifications and/or Project Plans.
- 1.15 **Technical Specifications:** The detailed Project requirements contained in Volume 3 of the Bid Package and any addenda to the Technical Specifications signed by authorized City representatives and issued prior to bid opening, Equal Product Proposals accepted by the City and signed by authorized City representatives prior to bid opening, and change orders and other amendments to the Technical Specifications signed by authorized representatives of the City and the Contractor in accordance with the requirements of the Contract Documents.
- 1.16 **Time for Completion:** The Time for Completion is the time by which the Work must be completed, as defined in the Contract, Part 1, or as modified in a writing, executed by the City and Contractor.
- 1.17 **Work:** The furnishing of all equipment, tools, apparatus, facilities, material, labor and skill necessary to perform and complete in a good and workmanlike manner the Project as shown in the Technical Specifications and Project Plans in accordance with the Contract Documents and applicable law.
- 1.18 **Written Notice:** Will be deemed to have been duly served for purposes of these General Provisions and any agreement of which they are a part if delivered in person to the individual or to a member of the firm or to any office of the corporation for whom the notice is intended, or if sent by registered or certified mail to the last known business address known to the party giving notice. Unless otherwise specified in the Contract Documents, the last known address of the Contractor shall be that listed in the Contractor's completed Proposal Cover Page and Bid Schedule.

## 2. PLANS AND SPECIFICATIONS

- 2.1 Documents Furnished by City. The City will furnish to the Contractor, free of charge, one (1) set of reproducible Project Plans and five (5) sets of prints of the Project Plans and Technical Specifications for execution of the Work. Throughout the performance of the Work the Contractor must keep one copy of the Project Plans and Technical Specifications in good order and available for review by the Construction Manager, the Engineer, the Architect, and any other City contractors or representatives.
- 2.2 Ownership of Documents Furnished by City. All documents furnished by the City, including, but not limited to, the Technical Specifications, Project Plans, and any copies, are the property of the City. Documents furnished by the City may not to be used on any other work. All documents furnished by the City must be returned to City upon completion of the Work.
- 2.3 Technical Specifications and Project Plans.
- 2.3.1 The Technical Specifications and Project Plans are complementary and intended to mutually describe the Work necessary to complete the Project in accordance with the Contract Documents.
- 2.3.2 In general, the Project Plans indicate dimensions, position and kind of construction, and the Technical Specifications indicate qualities and methods. Any Work indicated on the Project Plans and not mentioned in the Technical Specifications or vice versa must be furnished as though fully set forth in both. Work that is not particularly detailed, marked or specified shall be the same as similar Work that is detailed, marked or specified. The Contractor must furnish items necessary for the operation of equipment depicted in the Project Plans or specified in the Technical Specifications that are suitable to allow such equipment to function properly at no extra charge.
- 2.3.3 Contractor shall perform reasonably implied parts of Work as “incidental work” although absent from Drawings and Specifications. Incidental work includes any work not shown on Drawings or described in Specifications that is necessary or normally or customarily required as a part of the Work shown on Drawings or described in Specifications. Incidental work includes any work necessary or required to make each installation satisfactory, legally operable, functional, and consistent with the intent of Drawings and Specifications or the requirements of Contract Documents. Contractor shall perform incidental work without extra cost to City. Incidental work shall be treated as if fully described in Specifications and shown on



Drawings, and the expense of incidental work shall be included in price Bid and Contract Sum.

- 2.3.4 Before undertaking each portion of the Work, Contractor shall carefully study and compare the Contract Documents and check and verify pertinent figures shown in the Contract Documents and all applicable field measurements. Contractor shall be responsible for any errors that might have been avoided by such comparison. The Contractor must notify the Construction Manager and the Architect in writing as soon as possible of any apparent errors or inconsistencies, including, but not limited to, typographical or notational errors in the Project Plans, Technical Specifications, and/or in work done by others affecting the Work. The Construction Manager will issue written instructions concerning any such apparent errors, inconsistencies, or clarifications with reasonable promptness and these shall be binding on the Contractor. If Contractor believes that a written response, clarification or interpretation justifies an adjustment in the Contract Sum or Contract Time, Contractor shall give City prompt written notice. If the parties are unable to agree to the amount or extent of the adjustment, if any, then Contractor shall perform the Work in conformance with City's response, clarification, or interpretation and may make a written claim for the adjustment as provided in Section 11. If the Contractor proceeds with Work impacted by apparent errors or inconsistencies without instructions from the Construction Manager, the Contractor shall do so at its sole risk and shall have all of the obligations and the City shall have all of the rights and remedies specified in Section 11 concerning any resulting damage or defect.
- 2.3.5 The General Provisions apply with equal force to all of the Work, including extra work authorized by the Construction Manager in accordance with the Contract Documents. The Contractor must submit any required shop diagrams and/or drawings by the times and in the quantities indicated in the Technical Specifications. Any such shop diagrams and/or drawings must show completely the Work to be done, expanding on the Project Plans concerning details not previously shown, field conditions and the condition of the Work. Architect or Engineer review of such shop diagrams and/or drawings will concern conformance with the requirements of the Contract Documents only. The Architect or Engineer assumes no responsibility for the correctness or accuracy of the dimensions or any other contents of any shop diagrams and/or drawings submitted by the Contractor. The Contractor must check all dimensions at the Work site. Shop diagrams and/or drawings must be clearly marked with the name of the Project and the name of the Contractor, subcontractor or supplier making the submittal, and must be stamped and signed by the Contractor and submitted under a signed transmittal letter from the Contractor

City of Fort Bragg  
Project No. PWP-00127  
Contract, Part 2  
General Provisions

certifying that all dimensions have been checked at the Work site. These requirements are mandatory. The Architect or Engineer will not review shop diagrams and/or drawings that do not satisfy these requirements. The Contractor will be responsible for any and all discrepancies between dimensions of the actual Project site and/or Work and those shown on shop diagram and/or drawings submitted by the Contractor, and for any other errors contained in or resulting from such shop diagrams and/or drawings, including, but not limited to, errors in material and/or equipment quantities and any resulting errors, delays or additional cost in the performance of the Work. The Contractor will have all of the obligations and the City will have all of the rights and remedies that are specified in Section 11 concerning any discrepancies or errors in shop diagrams and/or drawings submitted by the Contractor, and concerning any resulting errors, delays or additional costs in the performance of the Work.

### 3. CONTROL OF WORK AND MATERIAL

- 3.1 Construction Manager's Status. The Construction Manager will administer the Project in accordance with the Contract Documents. After execution of the agreement and issuance of the Notice to Proceed, all correspondence and/or instructions concerning the Project between the Contractor and/or City shall be forwarded through the Construction Manager. Except as otherwise provided in the Contract Documents, the Construction Manager will not be responsible for and will not have control or charge of construction means, methods, techniques, or procedures or for safety precautions in connection with the Work. The Construction Manager, however, will have authority to reject materials and/or workmanship that do not conform to the requirements of the Contract Documents. The Construction Manager will also have the authority to require inspection or testing of the Work.
- 3.2 Architect or Engineer's Status. The Architect or Engineer will advise the Construction Manager concerning decisions on all claims of the Contractor and all other matters relating to the execution and progress of the Work or the interpretation of the Contract Documents. The Architect or Engineer will also advise the Construction Manger concerning Work that does not conform to the Contract Documents. Whenever, in the Architect's or Engineer's opinion, it is necessary or advisable in accordance with the Contract Documents, the Architect or Engineer may recommend to the Construction Manager inspection or testing of the Work, whether or not such Work is then fabricated, installed or completed.
- 3.3 Inspection and Testing of Work and Material.
  - 3.3.1 The City, the Construction Manager, the Architect or Engineer and their representatives will have access to the Work at all times wherever it is

in preparation or progress. The Contractor must provide proper facilities for such access and for inspection.

- 3.3.2 The Contractor must inspect all materials as delivered and promptly return all defective materials without waiting for their rejection by the Construction Manager or Architect or Engineer.
- 3.3.3 If the Construction Manager, the Technical Specifications, or any laws, ordinances, or any public authority require any Work to be tested or approved, the Contractor must give the Construction Manager timely notice of the Contractor's readiness for inspection. Inspections will be promptly made, and where practicable, at the source of supply. Any work subject to such testing that is covered up without timely notice to the Construction Manager or without the approval or consent of the Construction Manager must, if required by the Construction Manager, be uncovered for examination at the Contractor's expense. The Contractor will have all of the obligations and the City will have all of the rights and remedies that are specified in Section 11 concerning any work subject to testing that is covered up without timely notice to the Construction Manager and that is not uncovered for examination at the Contractor's Expense if required by the Construction Manager.
- 3.3.4 Tests of materials or qualification tests required by the Contract Documents must be made in accordance with the Technical Specifications and the requirements of the California Building Standards Code as adopted by the City and other applicable law. Copies of all testing reports shall be distributed as required in the Technical Specifications.
- 3.3.5 The City or its representatives may order re-examination of questioned Work. If ordered to do so, the Contractor must uncover such Work. If such Work is found to be according to the Contract Documents, the City shall pay the cost of uncovering and restoring the Work, unless such Work was subject to testing and covered up without timely notice to or approval of the Construction Manager. If re-examined Work is found not in accordance with the Contract Documents, the Contractor must pay the cost of uncovering and restoring the Work. The Contractor will have all of the obligations and the City will have all of the rights and remedies that are specified in Section 11 concerning any re-examined Work not in accordance with the Contract Documents that the Contractor fails to uncover and restore at the Contractor's expense.
- 3.3.6 The Contractor must replace or correct without charge any material or workmanship found not to conform to the requirements of the Contract Documents, unless the City consents to accept such material or workmanship with an appropriate adjustment in the Contract Price. The Contractor must promptly segregate and remove non-conforming

material from the Work site. The Contractor will have all of the obligations and the City will have all of the rights and remedies that are specified in Section 11 concerning any failure by the Contractor to replace or correct without charge any material or workmanship that does not conform to the requirements of the Contract Documents and that the City has not consented to accept.

3.4 Samples Furnished by the Contractor. The Contractor must furnish all samples for approval as directed in sufficient time to permit the Architect or Engineer to examine, approve and select samples before they are required by the progress of the Work. Portions of the Work for which samples are required and for which the Architect or Engineer has selected samples must be in accordance with such approved samples. Samples must be sent prepaid to the office of the Construction Manager or to such place as the Construction Manager may direct.

3.5 Materials and Substitutions.

3.5.1 Materials used for the Work must be new and of the quality specified. When not particularly specified, materials must be the best of their class or kind. The Contractor must, if required, submit satisfactory evidence as to the kind and quality of materials.

3.5.2 If the Contractor submitted complete information to the Public Works Department for products proposed as equals in accordance with the Bid Package, and the City approved such products proposed as equals in writing, the Contractor may either furnish such products approved as equals, or furnish the products listed by manufacturer name, brand or model number in the Technical Specifications or Project Plans. The City retains the right, in its sole discretion, to accept or reject any other proposed substitution. To be considered, proposals concerning products proposed as equals must include sufficient information to permit the City to determine whether the products proposed as equals will satisfy the same performance requirements as products listed by manufacturer's name, brand or model number. Such performance requirements may include, but are not limited to, size, strength, function, appearance, ease of maintenance and repair, and useful life requirements. If the City does not accept a proposed substitution, the Contractor must furnish the product specified in the Technical Specifications or Project Plans for the Contract Price, regardless of whether the product is specified by manufacturer's name, brand or model number, or otherwise.

3.5.3. During the performance of the Work, all materials must be neatly stacked, properly protected from the weather and other adverse impacts, and placed so as to avoid interference with efficient progress of the Work, with other activities of the City, or with the use of existing

City facilities by the public. All materials must be delivered so as to ensure efficient and uninterrupted progress of the Work. Materials must be stored so as to cause no obstruction and so as to prevent overloading of any portion of the Work. The Contractor will be responsible for damage or loss of materials delivered to and/or stored at the Work site due to weather or other causes. The Contractor must promptly remove from the Work site all materials rejected by the City or its representatives as failing to conform to the requirements of the Contract Documents, whether such non-conforming materials have been incorporated in the Work or not. If the City or its representatives so direct, the Contractor must promptly replace and re-execute Work performed by the Contractor and order the replacement and re-execution of Work performed by subcontractors using non-conforming materials with materials that satisfy the requirements of the Contract Documents without expense to the City. The Contractor will bear the expense of making good all Work destroyed or damaged by such removal. The Contractor will have all of the obligations and the City will have all of the rights and remedies that are specified in Section 11 concerning any failure by the Contractor to replace or re-execute Work using non-conforming materials, and/or to make good all work destroyed or damaged by such removal and/or execution.

- 3.6 Maintenance and Examination of Records. Contractor shall maintain in a safe place at the Site one record copy of all Drawings, Specifications, Addenda, Contract Modifications, Change Orders, Work Directives, Force Account orders, and written interpretations and clarifications in good order and annotated to show all as-built changes made during construction. These Project Record Documents, together with all approved Samples and a counterpart of all approved Shop Drawings, shall be maintained and available to the City for reference. Upon completion of the Work, Contractor shall deliver to the City, the Project Record Documents, Samples and Shop Drawings and as-built drawings.

Throughout Contractor's performance of the Work of the Project, Contractor shall maintain construction records to include: shop drawings; product data/material data sheets; samples; submittals; purchases; materials; equipment; inspections; applicable handbooks; applicable codes and standards; maintenance and operating manuals and instructions; RFI Log; Submittal Log; other related documents and revisions which arise out of the Construction Contracts. Contractor shall maintain records of principal building layout lines, elevations for the bottom of footings, floor levels, and key site elevations (certified by a qualified surveyor or professional engineer). Contractor shall make all records available to the City. At the completion of the Project, Contractor shall deliver all such records to the City to have a complete set of record as-built drawings.

The City may examine and audit at no additional cost to the City all books, estimates, records, contracts, documents, bid documents, bid cost data, subcontract job cost reports and other Project related data of the Contractor, subcontractors engaged in performance of the Work, and suppliers providing supplies, equipment and other materials required for the Work, including computations and projections related to bidding, negotiating, pricing or performing the Work or contract modifications and other materials concerning the Work, including, but not limited to, Contractor daily logs, in order to evaluate the accuracy, completeness, and currency of cost, pricing, scheduling and any other project related data. The Contractor will make available all such Project related data at all reasonable times for examination, audit, or reproduction at the Contractor's business office at or near the Work site, and at any other location where such Project related data may be kept until three years after final payment under the Agreement. Pursuant to California Government Code Section 8546.7, if the amount of public funds to be expended is in excess of \$10,000, this Contract shall be subject to the examination and audit of the State Auditor, at the request of the City, or as part of any audit of the City, for a period of three (3) years after final payment under the Agreement.

- 3.7 Advertising. No advertising signs of any kind may be displayed on the Work site, or on fences, offices or elsewhere adjacent to the Work site.
- 3.8 Project Schedule. Prior to the pre-construction meeting, the Contractor shall submit a baseline schedule showing each task of Work, including, as required by the City, equipment procurement and delivery (Contractor and City supplied), activities with Subcontractors and suppliers, major submittal reviews, commissioning of systems, use of major equipment on site, and necessary interface with the City and third parties. The baseline schedule shall include the sequence of each task, the number of days required to complete each task, and the critical path controlling the completion of the entire Work. The schedule shall allow for the completion of the entire Work within the Time for Completion.
  - 3.8.1 City Review of Schedule. The City may review the Contractor's submitted schedule and may note any exceptions. The Contractor shall correct any exceptions noted by the City within five (5) working days of being notified of the exceptions.
  - 3.8.2 Update of Schedule. After submission of a schedule to which the City has taken no exceptions, the Contractor shall submit an updated schedule on a biweekly basis until completion of the Work. The updated schedule shall show the progress of Work as of the date specified in the updated schedule. Contractor shall provide the City with an electronic copy of each updated schedule.

- 3.8.3 Float. The baseline schedule and all later submitted schedules shall show early and late completion dates for each task. The number of days between these dates shall be designated as "Float." The Float shall be designated to the Project and shall be available to both the City and the Contractor as needed to complete the Work in accordance with the Contract.
- 3.8.4 Failure to Submit Schedule. If the Contractor fails to submit the schedule within the time period specified in this section or submit a schedule to which the City has taken uncorrected exceptions, the City may withhold payments to the Contractor until such schedules are submitted and/or corrected in accordance with the Contract documents.
- 3.8.5 Responsibility for Schedule. The Contractor will be solely and exclusively responsible for creating the schedule and properly updating it. The City may note exceptions to any schedule submitted by the Contractor. However, the Contractor will be solely responsible for determining the proper method of addressing such exceptions, and the City's review of the schedule will not create scheduling obligations for the City.
- 3.8.6 Contractor's baseline schedule and progress schedules shall be in the form of a CPM (arrow) diagram. Contractor shall provide the City with native format electronic schedules and hard copies of the baseline schedule, schedule updates, and look ahead schedules. All electronic and hard copies of the schedule that Contractor provides to the City shall indicate the critical path of the Work (in red) and shall show a logical progression of the Work through completion within Contract Time.
- 3.8.7 The City has no obligation to accept an early completion date.
- 3.8.8 The City may request a recovery schedule should Contractor fall 21 or more Days behind any schedule milestone, which schedule shall show Contractor's plan and resources committed to retain Contract completion dates. The recovery schedule shall show the intended critical path. If the City requests, Contractor shall also: secure and demonstrate appropriate subcontractor and supplier consent to the recovery schedule; and submit a written plan and narrative explaining on trade flow and construction flow changes and man-hour loading assumptions for major Work activities and/or subcontractors.
- 3.8.9 If the Contractor requests an extension of the Time for Completion, it shall submit the request in a writing that provides information justifying the request and stating the extent of the adjustment requested for each specific change or alleged delay. The writing shall include this narrative and a schedule diagram depicting how the changed Work or other

impact affects other schedule activities. The schedule diagram shall show how Contractor proposes to incorporate the changed Work or other impact in the schedule and how it impacts the current schedule impact or critical path or otherwise. Any requests of an extension of the Time for Completion stemming from an alleged project delay shall be made within five (5) days of the commencement of the alleged delay, explain the reason for delay, include the anticipated length of the delay, and contain a narrative justifying the extension, in addition to the other information and schedules required by this section.

- 3.9 Construction Staking. All Work done under this Contract must be in conformance with the Project Plans and staked by the Engineer in the field. The Contractor must inform the Engineer, forty-eight (48) hours in advance, of the time and places at which he or she wishes to do work, in order that lines and grades may be furnished and necessary measurements for record and payment made, with the minimum of inconvenience to the Engineer and delay to the Contractor.
- 3.10 Materials Testing. Materials will be tested by the CITY OF FORT BRAGG or its authorized agent, following State of California Test Methods. Statistical testing may not be used. All individual samples must meet the specified test results. Each material used must meet the specified requirements.

The Contractor must request and coordinate all testing. All tests must occur in the presence of the Project Inspector. The City will, at its sole discretion, have the right to reject any and/or all test results that do not meet this requirement, and to order a retest in the presence of the Project Inspector. The costs for all retests so ordered will be the responsibility of the Contractor. The cost of all retests will be charged to the Contractor at the actual cost plus 30 percent, with a minimum charge of \$150.00 per test to cover staff and administrative costs.

The City, at its sole expense, will provide all initial material and compaction tests. Sampling and testing will comply with Chapter 6 of the Caltrans Construction Manual, at a minimum. Where conditions vary, the City may perform additional testing. Cost for testing of materials offered in lieu of the specified materials will be the responsibility of the Contractor. Cost for R-value tests when required by the Standard Specifications will be the responsibility of the Contractor.

Testing will only be performed on normal City working days between the hours of 8:00 a.m. and 4:00 p.m. unless other arrangements are made in advance. Tests performed outside of these hours may be subject to increased charges.

The Contractor must request all tests in writing a minimum of two (2) working days in advance of the time desired. A minimum of one working day must be allowed for compilation and reporting of data and test results after tests have

City of Fort Bragg  
Project No. PWP-00127  
Contract, Part 2  
General Provisions



been performed. No subsequent layer of material may be placed until a passing test is obtained and acknowledged by the City.

Concrete and asphalt may be supplied only from suppliers approved and certified by the State Department of Transportation. Proposed mix designs for all concrete and asphalt concrete to be placed within the CITY OF FORT BRAGG must be provided to and approved by the City, prior to placement.

The Contractor must coordinate with the City concerning any additional testing as required.

#### 4. CHANGES IN WORK

- 4.1 City Directed Change Orders. The City may at any time during the progress of the Work direct any amendments to the Work or any of the Contract Documents, including, but not limited to the Technical Specifications, or Project Plans. Such amendments will in no way void the agreement, but may be applied to amend the Contract Price or Time for Completion, if such amendments affect the Contract Price, the Project schedule, or any other provision of the Contract Documents based on a fair and reasonable valuation of the amendment in accordance with this Section 4.
- 4.2 Writing Requirement. Change orders and other amendments to the Technical Specifications, the Project Plans, or other Contract Documents may be made only by a writing executed by authorized representatives of the City and the Contractor.
- 4.3 Contractor Proposed Change Orders. Unless the Construction Manager otherwise authorizes or the City and the Contractor otherwise agree, change order proposals submitted by the Contractor must be submitted to the Construction Manager no later than the time of the proposed change.
- 4.4 All Change Orders. All change order proposals must be submitted on completed Change Order forms provided by the City. All such change order proposals must itemize all cost impacts of the proposed change order and include a total price for that change order and the amended Contract Price that would become effective upon execution of the change order. All change order proposals must specify any change in the Project schedule, or in any project milestone including, but not limited to, the Time for Completion, under the change order, and must provide information justifying the requested change in the Time for Completion. It is understood that change orders that do not specify a change in any milestone, including, but not limited to, the Time for Completion, will be accomplished by the Time for Completion then in effect.
- 4.5 Change Order Pricing. Change order pricing will be governed by the following:

- 4.5.1 Unit prices specified in the Contract Documents will apply to cost impacts involving items for which the Contract Documents specify unit prices.
- 4.5.2 Cost impacts involving items for which no unit prices are specified will be calculated by adding the itemized actual direct cost that would be added or reduced under the change order and an allowance for indirect costs in accordance with this Section. Itemization for direct costs for required labor must include the classifications of labor required, the total hours required for each classification, the hourly rate for each classification and other labor related costs such as liability and workers compensation insurance, social security, retirement and unemployment insurance. All other cost impacts for which no unit prices are specified must be itemized as appropriate, including the cost of tools, vehicles, phones and other equipment, and the cost of all required materials or supplies. Indirect costs added under a change order may not exceed an allowance of fifteen (15) percent of the total of combined Contractor and subcontractor direct costs added under the change order. Such allowance covers Contractor overhead and profit under the change order and includes the cost of insurance in addition to that required pursuant to Section 8.8, bond premiums, superintendent labor, clerical labor, home office expenses, worksite office expenses, and utility costs under the change order. Such costs may not be itemized as direct costs under a change order. Indirect costs deducted under a change order will be calculated in exactly the same way as indirect costs added under a change order, except indirect costs deducted under a change order may not exceed an allowance of seven and a half (7.5) percent of the total of combined Contractor and subcontractor direct costs deducted under the change order.
- 4.6 Liability Under Unapproved Change Orders. The Contractor shall be solely responsible for any and all losses, costs, or liabilities of any kind incurred by the Contractor, any subcontractor engaged in the performance of the Work, any party supplying material or equipment for the Work or any third party that are incurred pursuant to Contractor-proposed change orders prior to issuance of an approved change order executed in accordance with this Section 4. The Contractor will have all of the obligations and the City will have all of the rights and remedies that are specified in Section 11 concerning any work or resulting losses, costs, or liabilities pursuant to a Contractor proposed change order before issuance of an approved change order executed in accordance with this Section 4.
- 4.7 Changes Subject to Contract Documents. Any changes in the Work and/or the Contract Documents pursuant to change orders and any other amendments issued in accordance with the Contract Documents, including

this Section 4, will in all respects be subject to all provisions of the Contract Documents, including, but not limited to, the Technical Specifications and the Project Plans, except as modified by such change orders or amendments.

#### 4.8 Change Order Disputes.

4.8.1 Disputed City Directed Change Orders. If the Contractor disputes a City directed change order following a reasonable effort by the City and the Contractor to resolve the dispute including, at a minimum, a meeting between appropriate representatives of the Contractor and the City, the Contractor must commence performing the Work consistent with the disputed change order within five (5) working days of the last meeting between representatives of the Contractor and the City to resolve the dispute, or within the time specified in the disputed City directed change order, whichever is later. In performing Work consistent with a disputed City-directed change order pursuant to this provision the Contractor will have all of the Contractor's rights concerning claims pursuant to the Contract Documents and applicable law.

4.8.2 Disputed Contractor Proposed Change Orders. If the City disputes a Contractor proposed change order, the City and the Contractor will use reasonable efforts to resolve the dispute including, at a minimum, holding a meeting between appropriate representatives of the Contractor and the City. Regardless of and throughout any such efforts to resolve the dispute the Contractor must continue performing the Work irrespective of and unmodified by the disputed change order. In continuing to perform the Work, the Contractor will retain all of the Contractor's rights under contract or law pertaining to resolution of disputes and protests between contracting parties. Disputes between the City and the Contractor concerning any Contractor-proposed change order or other amendment do not excuse the Contractor's obligation to perform the Work in accordance with the Contract Documents excluding such Contractor-proposed change order or other amendment by the Time for Completion or waive any other Project milestone or other requirement of the Contract Documents.

4.9 Change in Time for Completion. The Time for Completion may only be changed through a Change Order, and all time limits stated in the Contract Documents are to mean that time is of the essence. Contractor shall not be entitled time extension for impacts that consume Float, but do not impact the critical path. Time extensions will not be granted unless substantiated by the Critical Path Method (CPM) Schedule, and then not until the CPM float becomes zero. If contractor fails to submit documentation requesting and justifying a change in Time for Completion consistent with the Contract Documents, the Contractor shall be deemed to have agreed that there is no

City of Fort Bragg  
Project No. PWP-00127  
Contract, Part 2  
General Provisions

extension of time and that Contractor has irrevocably waived its rights to any change in the Time for Completion. Contractor initiated change orders shall address any impacts on the Time for Completion when first submitted to the City. Contractor shall submit any request for change in the Time for Completion and all supporting information and documentation required by the Contract Documents within seven (7) working days of receipt of a City-directed Change Order.

## 5. TRENCHING AND UTILITIES

- 5.1 Contractor to Locate Underground Facilities. During construction, Contractor shall comply with Government Code Sections 4216 to 4216.9, and in particular Section 4216.2 which provides, in part: "Except in an emergency, every person planning to conduct any excavation shall contact the appropriate regional notification center at least two working days, but no more than 14 calendar days, prior to commencing that excavation, if the excavation will be conducted in an area which is known, or reasonably should be known, to contain subsurface installations other than the underground facilities owned or operated by the excavator, and, if practical, the excavator shall delineate with white paint or other suitable markings the area to be excavated. The regional notification center shall provide an inquiry identification number to the person who contacts the center and shall notify any member, if known, who has a subsurface installation in the area of the proposed excavation."

Contractor shall contact Underground Service Alert (USA), and schedule the Work to allow ample time for the center to notify its members and, if necessary, for any member to field locate and mark its facilities. Contractor is charged with knowledge of all subsurface conditions reflected in USA records. Prior to commencing excavation or trenching work, Contractor shall provide the City with copies of all USA records secured by Contractor. Contractor shall advise the City of any conflict between information in the Contract Documents, Drawings, independent investigations, and that provided by USA records. Contractor's excavation shall be subject to and comply with the Contract Documents.

Contractor shall also investigate the existence of existing service laterals, appurtenances or other types of utilities, indicated by the presence of an underground transmission main or other visible facilities, such as buildings, manholes, new asphalt, meters and junction boxes, on or adjacent to the Site, even if not shown or indicated in existing conditions data, Contract Documents, or USA records, or discovered during Contractor's pre- or post-bid investigation. Contractor shall immediately secure all such available information and notify the City and the utility City, in writing, of its discovery.

- 5.2 Excavation More Than Four Feet Deep. In accordance with California Public Contract Code Section 7104, if the Work involves excavation more than four feet deep the Contractor must promptly notify the City in writing before

City of Fort Bragg  
Project No. PWP-00127  
Contract, Part 2  
General Provisions

disturbing: any material that the Contractor believes may be hazardous waste, as defined in Section 25117 of the Health and Safety Code, that is required to be removed to a Class I, Class II or Class III disposal site in accordance with provisions of existing law; any subsurface or latent physical conditions at the Work site differing from those indicated; or any unknown physical conditions at the Work site of any unusual nature, different materially from those ordinarily encountered and generally recognized as inherent in work of the character provided for in the Contract Documents. The City will promptly investigate any such conditions for which notice is given. If the City finds that the conditions do materially differ, or involve hazardous waste, and would cause a decrease or increase in the cost or time of performance of the Work, the City will issue a change order pursuant to Section 4 of these General Provisions. If a dispute arises between the City and the Contractor concerning whether the conditions materially differ, or involve hazardous waste, or cause a decrease or increase in the cost or time of performance, the Contractor will not be excused from any completion date provided in the Contract Documents, but shall proceed with all Work to be performed. The Contractor will retain all rights under contract or law pertaining to resolution of disputes and protests between contracting parties.

5.3 Excavation of Five Feet or More. In accordance with California Labor Code Section 6705, contractors performing contracts exceeding \$25,000 in cost and involving excavation five or more feet deep must submit for the City's acceptance, prior to excavation, a detailed plan showing the design of shoring, bracing, sloping, or other provisions to be made for worker protection from the hazard of caving ground during excavation. If the plan varies from the shoring system standards, it must be prepared by a registered civil or structural engineer.

5.4 Utility Relocation Costs.

5.4.1 In accordance with California Government Code Section 4215, the City assumes the responsibility for the timely removal, relocation or protection of existing main or trunkline utility facilities located on the Work site if such utilities are not identified by the City in the Technical Specifications and/or Project Plans. The City will compensate the Contractor for the costs of locating, repairing damage not due to the Contractor's failure to exercise reasonable care, and removing or relocating existing main or trunkline utility facilities located at the Work site and not identified with reasonable accuracy in the Technical Specifications and/or Project Plans. The City will also compensate the Contractor for the cost of equipment on the Project necessarily idled during such work. The Contractor will not be assessed liquidated damages for Work completion delays caused by the City's failure to provide for removal or relocation of such main or trunkline utility facilities.

- 5.4.2 Nothing in this provision or the Contract Documents will be deemed to require the City to indicate the presence of existing service laterals or appurtenances whenever the presence of such utilities on the Work site can be inferred from the presence of other visible facilities, such as buildings, meter and junction boxes, on or adjacent to the Work site; provided, however, that nothing in this provision or the Contract Documents shall relieve the City from identifying main or trunklines in the Technical Specifications and/or Project Plans.
  - 5.4.3 Nothing in this provision or the Contract Documents will preclude the City from pursuing any appropriate remedy against the utility for delays which are the responsibility of the utility.
  - 5.4.4 Nothing in this provision or the Contract Documents will be construed to relieve the utility from any obligation as required either by law or by contract to pay the cost of removal or relocation of existing utility facilities.
  - 5.4.5 If the Contractor while performing the Work discovers utility facilities not identified by the City in the Technical Specifications and/or Project Plans, the Contractor must immediately notify the City and utility in writing.
  - 5.4.6 Either the City or the utility, whichever owns existing main or trunkline utility facilities located on the Work site, shall have sole discretion to effect repairs or relocation work or to permit the Contractor to perform such repairs or relocation work at a reasonable price.
- 5.5 Concealed or Unknown Conditions.
- 5.5.1 If either of the following conditions is encountered at Site when digging trenches or other excavations that extend deeper than four feet below the surface, Contractor shall promptly give a written Notice of Differing Site Conditions to the City before conditions are disturbed, except in an emergency, and in no event later than seven (7) calendar days after first observance of:
    - 5.5.1.1 Subsurface or Latent physical conditions which differ materially from those indicated in the Contract Documents;  
or
    - 5.5.1.2 Unknown physical conditions of an unusual nature or which differ materially from those ordinarily encountered and generally recognized as inherent in work of the character provided for in the Contract Documents.
  - 5.5.2 In response to Contractor's Notice of Differing Site Conditions under this Section, the City will investigate the identified conditions, and if they differ materially and cause increase or decrease in Contractor's

cost of, or time required for, performance of any part of the Work, the City will negotiate the appropriate change order following the procedures set forth in the Contract Documents. If the City determines that physical conditions at the Project are not latent or are not materially different from those indicated in Contract Documents or that no change in terms of the Contract Documents is justified, the City will so notify Contractor in writing, stating reasons (with Contractor retaining all rights under the Contract Documents).

- 5.5.3 Contractor shall not be entitled to any adjustment in the Contract Sum or Contract Time regarding claimed latent or materially different Project conditions (whether above or below grade) if Contractor knew or should have known of the existence of such conditions at the time Contractor submitted its Bid, failed to give proper notice, or relied upon information, conclusions, opinions or deductions of the kind that the Contract Documents preclude reliance upon.
- 5.5.4 Regarding Underground Facilities, Contractor shall be allowed an increase in the Contract Sum or an extension of the Time for Completion, or both, to the extent that they are attributable to the existence of any Underground Facility that is owned and was built by the City only where the Underground Facility:
  - 5.5.4.1 Was not shown or indicated in the Contract Documents or in the information supplied for bidding purposes or in information on file at USA; and;
  - 5.5.4.2 Contractor did not know of it; and
  - 5.5.4.3 Contractor could not reasonably have been expected to be aware of it or to have anticipated it from the information available. (For example, if surface conditions such as pavement repairs, valve covers, or other markings, indicate the presence of an Underground Facility, then an increase in the Contract Sum or an extension of the Time for Completion will not be due, even if the Underground Facility was not indicated in the Contract Documents, in the information supplied to Contractor for bidding purposes, in information on file at USA, or otherwise reasonably available to Contractor.)
- 5.6 Contractor shall bear the risk that Underground Facilities not owned or built by the City may differ in nature or locations shown in information made available by the City for bidding purposes, in information on file at USA, or otherwise reasonably available to Contractor. Underground Facilities are inherent in construction involving digging of trenches or other excavations on City's Project, and Contractor is to apply its skill and industry to verify the information available.

5.7 Contractor's compensation for claimed latent or materially different Project conditions shall be limited to the actual, reasonable, incremental increase in cost of that portion of the Work, resulting from the claimed Latent or materially different Site conditions. Such calculation shall take into account the estimated value of that portion of the Work and the actual value of that portion of the Work, using for guidance Contractor's or its subcontractor's bid amount and actual amounts incurred for that portion of the Work and the reasonable expectation (if any) of differing or difficult site conditions in the Work area based on the available records and locale of the Work. For example, if Contractor excavates in an area unexpected, then such costs would be recoverable entirely; while if Contractor extends an existing excavation, then such costs would be recoverable if the resulting excavation costs in that work area exceeded the reasonable expectations therefor.

## 6. PROJECT FACILITIES

6.1 Work Site Offices. Any Work site office facilities used by the Contractor and/or its privities must conform to all applicable codes, ordinances and regulations. The cost of such Work site office facilities shall be paid from and included in the Contract Price.

6.2 City Rights of Access and Ownership. The City and its authorized representatives will at all reasonable times while such office facilities are located at the Work site (including, at a minimum, all times during which the Work is performed), have access to any such Work site office facilities used by the Contractor and/or its privities. With respect to the right of access of the City and its authorized representatives, neither the Contractor nor its privities shall have a reasonable expectation of privacy pursuant to the Fourth Amendment to the United States Constitution or other applicable law concerning such Work site office facilities used by the Contractor and/or its privities. Without exception, any and all Project related materials located at such Work site facilities will be deemed at all times to be City property subject to inspection and copying by the City and its authorized representatives at all reasonable times while such facilities are located at the Work site (including, at a minimum, all times during which the Work is performed). Any interference by the Contractor or its privities with the City's rights of access and/or Ownership pursuant to this Section 6 will constitute a material breach of the Agreement subject to any and all remedies available pursuant to the Contract Documents and at law and equity.

## 7. PROSECUTION AND PROGRESS OF THE WORK

7.1 Liquidated Damages. Time is of the essence in the Agreement. The City and the Contractor agree that it will be difficult and/or impossible to determine the actual damage which the City will sustain in the event of the Contractor's failure to fully perform the Work or to fully perform all of the Contractor's obligations that have accrued pursuant to the Agreement by the Time for

City of Fort Bragg  
Project No. PWP-00127  
Contract, Part 2  
General Provisions



Completion. Accordingly, the City and the Contractor agree in accordance with California Government Code Section 53069.85 that the Contractor will forfeit and pay to the City liquidated damages in the sum of \$500 per day for each and every calendar day completion of the Work and/or performance of all of the Contractor's obligations that have accrued pursuant to the Agreement is delayed beyond the Time for Completion. The City and the Contractor further agree in accordance with California Government Code Section 53069.85 that the liquidated damages sum specified in this provision is not manifestly unreasonable under the circumstances existing at the time the Agreement was made, and that the City may deduct liquidated damages sums in accordance with this provision from any payments due or that may become due the Contractor under the Agreement.

- 7.2 No Damage for Avoidable Delays. All delays in the Work that might have been avoided by the exercise of care, prudence, foresight and diligence of the Contractor or any privities of the Contractor will be deemed avoidable delays. Delays in the Work that may be unavoidable but that do not necessarily affect other portions of the Work or prevent completion of all Work within the Time for Completion, including, but not limited to, reasonable delays in Engineer approval of shop drawings, placement of construction survey stakes, measurements and inspection, and such interruption as may occur in prosecution of the Work due to reasonable interference of other contractors of the City, will be deemed avoidable delays. The Contractor will not be awarded a change in the Project schedule, the Time for Completion, and/or additional compensation in excess of the contract price for avoidable delays.
- 7.3 Unavoidable Delays. All delays in the Work that result from causes beyond the control of the Contractor and that the Contractor could not have avoided through exercise of care, prudence, foresight, and diligence will be deemed unavoidable delays. Orders issued by the City changing the amount of Work to be done, the quantity of materials to be furnished, or the manner in which the work is to be prosecuted, and unforeseen delays in the prosecution of the Work due to causes beyond the Contractor's control, such as strikes, lockouts, labor disturbances, fires, epidemics, earthquakes, acts of God, neglect by utility owners or other contractors that are not privities of the Contractor will be deemed unavoidable delays to the extent they actually delay the Contractor's completion of the Work. The Contractor will be awarded a change in the Project schedule, the Time for Completion, and/or additional compensation in excess of the Contract Price for unavoidable delays to the extent such delays actually delay the Contractor's completion of the Work and/or result in the Contractor incurring additional costs in excess of the Contract Price.
- 7.4 No Damage for Contractor Caused Delay. Contractor shall not be entitled to additional compensation for extended field or home office overhead, field supervision, costs of capital, interest, escalation charges, acceleration costs or other impacts for any delays to the extent such delays are caused by the

failure of the Contractor or any subcontractor or other entity engaged in performance of the Work to perform the Work in accordance with the Contract Documents.

7.5 No Damage for Other Delay. Contractor will not be entitled to damages for delay to the Work caused by the following, which the City and Contractor agree will be deemed for purposes of California Public Contract Code Section 7102 either not caused by the City, and/or within the contemplation of the City and the Contractor, and/or reasonable under the circumstances:

7.5.1 Exercise of the City's right to sequence the Work in a manner that would avoid disruption to the City and other contractors based on: the failure of the Contractor or any subcontractor or other entity engaged in the performance of the Work to perform the Work in accordance with the Contract Documents, enforcement by the City or any other governmental agency of competent jurisdiction of any government act or regulation, or enforcement by the City of any provisions of the Agreement.

7.5.2 Requests for clarification or information concerning the Contract Documents or proposed change orders or modifications to the Contract Documents, including extensive and/or numerous such requests for clarification or information or proposed change orders or modifications, provided such clarifications or information or proposed change orders or modifications are processed by the City or its representatives in a reasonable time in accordance with the Contract Documents.

7.6 Delays Caused by the City and/or Its Privities. Delay caused by the City and/or other Contractors of the City will be deemed unavoidable delays. Either the City or the Contractor may propose a change in the Time for Completion for delays that are purported to be caused by the City and/or its privities and that are not reasonable under the circumstances involved and/or that are not within the contemplation of the City and the Contractor. Such proposed changes in the Time for Completion will constitute change order proposals subject to Section 4. In accordance with Section 4, the City and the Contractor may agree upon pricing for the cost impacts, if any, resulting from such delays. If such pricing is in anticipation of cost impacts that may, but have not yet occurred, the City will be obligated to pay the Contractor for such anticipated impacts in accordance with the Agreement and any applicable, approved change orders only to the extent the Contractor actually incurs the anticipated cost impacts. Notwithstanding anything to the contrary in Section 4, the City and the Contractor may agree to a daily rate or cap or lump sum that will apply to the cost impacts, if any, resulting from delay purportedly caused by the City and/or its privities subject to this provision. However, if such daily rate or cap or lump sum is in anticipation of cost impacts that have not yet occurred, the City will be obligated to pay such daily rate or cap or lump sum only to the extent the Contractor actually incurs such cost impacts.

City of Fort Bragg  
Project No. PWP-00127  
Contract, Part 2  
General Provisions

- 7.7 Weather Delays. Extensions of the Time for Completion will not be allowed for normal, adverse weather conditions that are consistent with historical weather data of the National Oceanographic and Atmospheric Administration of the U.S. Department of Commerce for the record station that is nearest or most applicable to the Work site. The Contractor should understand that normal adverse weather conditions are to be expected and plan the Work accordingly, such as by incorporating into the Project schedule, normal adverse weather delays as reflected in historical data of the National Oceanic and Atmospheric Administration of the U.S. Department of Commerce for the weather station most applicable to the Work site. Extensions of the Time for Completion for delays due to adverse weather will be allowed only if the number of adverse weather days far exceeds the historical data. No extensions of the Time for Completion will be granted for normal, adverse weather conditions or for adverse weather conditions that merely result in delays that do not or would not, themselves, result in failure to complete the Work by the Time for Completion.
- 7.8 Delay Claims. Within five (5) days of the beginning of any delay, Contractor shall notify the City in writing, by submitting a notice of delay that shall describe the anticipated delays resulting from the delay event in question. Whenever the Contractor claims a delay for which the Time for Completion may be extended, the Contractor must request an extension of time within five (5) days of submitting its notice of delay. The request must be in writing in the form of a change order and describe in detail the cause for the delay, and, if possible, the foreseeable extent of the delay. The City will determine all claims and adjustments in the Time for Completion. No claim for an adjustment in the Time for Completion will be valid and such claim will be waived if not submitted in accordance with the requirements of this Section and Section 4.9. In cases of substantial compliance with the notice timing requirements of this Section (but not to exceed twenty-one (21) days from the beginning of the delay event), City may in its sole discretion recognize a claim for delay accompanied with the proper documentation and justification, provided the Contractor also shows good faith and a manifest lack of prejudice to the City from the late notice.
- 7.9 Contractor Coordination of the Work.
- 7.9.1 The City reserves the right to do other work in connection with or in the vicinity of the Project by contract or otherwise, and Contractor shall at all times conduct the Work so as to impose no hardship on the City, others engaged in the Work or other contractors working at the Work site. The Contractor will adjust, correct and coordinate the Work with the work of others so that no delays result in the Work or other work at or near the Work site.
- 7.9.2 If any part of the Work depends for proper execution or results upon the work of the City or any other contractor, the Contractor will, before

City of Fort Bragg  
Project No. PWP-00127  
Contract, Part 2  
General Provisions

proceeding with such Work, promptly report to the City any apparent discrepancies or defects in such other Work. Failure of the Contractor to promptly report any apparent discrepancy or defect will be deemed an acceptance of the City's or other contractor's Work as fit and proper.

- 7.9.3 The Contractor will anticipate the relations of the various trades to the progress of the Work and will ensure that required anchorage or blocking is furnished and set at proper times. Anchorage and blocking necessary for each trade shall be part of the Work except where stated otherwise.
- 7.9.4 The Contractor will provide proper facilities at all times for access of the City, the Construction Manager, Architect or Engineer, and other authorized City representatives to conveniently examine and inspect the Work.

## 8. CONTRACTOR RESPONSIBILITIES

- 8.1. Eligibility. By executing the Agreement, the Contractor certifies that the Contractor is not ineligible to perform work on public works projects pursuant to California Labor Code Sections 1777.1 or 1777.7. In accordance with California Public Contract Code Section 6109(a), contractors who are ineligible to perform work on public works projects pursuant to California Labor Code Sections 1777.1 or 1777.7 may neither bid on, be awarded or perform the Work. To the fullest extent permitted by law, the Contractor shall hold harmless and indemnify the City from and against any and all damages, costs, and liability arising from or as a consequence of any violation of Public Contract Code Section 6109.
- 8.2 Non Discrimination. During the performance of this Contract, Contractor will not discriminate against any employee or subcontractor of the Contractor or applicant for employment because of race, religion, creed, color, national origin, gender, sexual orientation, or age. Contractor will take affirmative action to ensure that applicants are employed and that employees are treated during employment without regard to their race, religion, creed, color, national origin, gender, sexual orientation, or age.

Contractor acknowledges that Contractor, and all subcontractors hired by Contractor to perform services under this Agreement, are aware of and understand the Immigration Reform and Control Act ("IRCA"). Contractor is and shall remain in compliance with the IRCA and shall ensure that any subcontractors hired by Contractor to perform services under this Agreement are in compliance with the IRCA. In addition, Contractor agrees to indemnify, defend and hold harmless City, its agents, officers and employees, from any liability, damages or causes of action arising out of or relating to any claims that Contractor's employees, or employees of any subcontractor hired by Contractor, are not authorized to work in the United States for Contractor or its

subcontractor and/or any other claims based upon alleged IRCA violations committed by Contractor or Contractor's subcontractors.

- 8.3 Supervision of the Work. The Contractor will be solely responsible for the performance of the Work, including portions of the Work to be performed by subcontractors. The Contractor is charged with ensuring that all orders or instructions from the City, Construction Manager or Architect are disseminated to and followed by all subcontractors engaged in performance of the Work. The Contractor will supervise the Work using the Contractor's best skill and attention. At any time during the progress of the Work, the City, the Construction Manager, or the Architect may require the Contractor and/or subcontractors engaged in performance of the Work to attend a project meeting and the Contractor will attend, and ensure the attendance of any subcontractors whose attendance is required by the City and/or advisable in light of the matters to be addressed at the meeting.
- 8.4 Contractor's Superintendent. The Contractor will keep on the Work, throughout its progress, a competent superintendent and any necessary assistants, all satisfactory to the City. The superintendent may not be changed without the consent of the City. The superintendent will represent the Contractor and all directions given by the City to the superintendent will bind the Contractor in accordance with the Agreement. Superintendent time included in Contractor's completed bid schedule and/or in approved change orders, if any, must be included in Contractor's approved overhead rate and may not be charged as a direct cost.
- 8.5 Competent Employees. The Contractor must at all times enforce strict discipline and good order among the Contractor's employees and may not employ on the Project any unfit person or anyone not skilled in the Work assigned, or anyone incompetent or unfit for the duties of that person. When the City determines that a Contractor employee does not satisfy the requirements of this provision, upon notice from the City, the Contractor must ensure that employee performs no further Work and is no longer present at the Work site. Any such Contractor employee may not again be employed on the Project without City approval.
- 8.6 Items Necessary for Proper Completion of the Work. Except as otherwise noted in the Contract Documents, the Contractor will provide and pay for all labor, materials, equipment, permits, fees, licenses, facilities and services necessary for the proper execution and timely completion of the Work in accordance with the Contract Documents.
- 8.7 Construction Reports. The Contractor must submit daily construction reports detailing the daily progress of the Work to the Construction Manager on a weekly basis.
- 8.8 Subcontracting. The Contractor must perform with his or her own organization, a value of work amounting to not less than fifty percent (50%) of

the Contract amount, except that the bid amount for subcontracted “Specialty Items” so designated in the Special Provisions may be eliminated from the Contract amount and not considered as sub-contracted for the purposes of calculating the value of work to be performed by the Contractor. For the purposes of determining the value of work to be performed by the Contractor pursuant to this provision, materials, equipment, incidentals, etc., shall be considered to have been purchased by the Contractor or Subcontractor that is to install them. Where a portion of an item is subcontracted, the value of work subcontracted will be based on the estimated cost of such portion of the subcontracted item, as determined from information submitted by the Contractor, subject to approval by the Engineer.

8.8.1 By executing the Contract, the Contractor certifies that no subcontractor included on the list of proposed subcontractors submitted with the Contractor’s bid is ineligible to perform work on public works projects pursuant to California Labor Code Sections 1777.1 or 1777.7. In accordance with California Public Contract Code Section 6109(a), subcontractors who are ineligible to perform work on public works projects pursuant to California Labor Code Sections 1777.1 or 1777.7 may neither bid on, be awarded or perform as a subcontractor on the Work. In accordance with California Public Contract Code Section 6109(b), any contract on a public works project entered into between a contractor and a debarred subcontractor is void as a matter of law. The Contractor will ensure that no debarred subcontractor receives any public money for performing the Work, and any public money that may have been paid to a debarred subcontractor for the Work is returned to the City. The Contractor will be responsible for payment of wages to workers of a debarred subcontractor who has been allowed to perform the Work.

8.8.2 The Agreement and the performance of the Work are subject to the requirements of the Subletting and Subcontracting Fair Practices Act codified at California Public Contract Code Section 4100 et seq. If the Contractor fails to specify a subcontractor or specifies more than one subcontractor for the same portion of the Work in excess of one-half of one percent of the Contractor’s total bid, the Contractor agrees that the Contractor is fully qualified to perform that portion of the Work with the Contractor’s own forces, and that the Contractor will perform that portion of the Work with the Contractor’s own forces. If after award of the Agreement the Contractor subcontracts, except as provided for in California Public Contract Code Sections 4107 or 4109, any such portion of the Work, the Contractor will be subject to the penalties set forth in California Public Contract Code Sections 4110 and 4111, including cancellation of the Agreement, assessment of a penalty of up to 10 percent of the amount of the subcontract, and disciplinary action by the Contractors State License Board.

City of Fort Bragg  
Project No. PWP-00127  
Contract, Part 2  
General Provisions

- 8.8.3. No contractual relationship exists between the City and any subcontractor engaged in performance of the Work.
- 8.8.4 Incorporation of Contract Documents. The Contractor must incorporate the Contract Documents in each contract with a subcontractor engaged in the performance of the Work including the indemnity and insurance requirements to the extent they apply to the scope of the subcontractor's work. The Contractor shall be solely responsible for any delay or additional costs incurred as a result of its failure to provide adequate or accurate project information to a subcontractor that results in improper submittals and/or work, or time or other impacts is the sole responsibility of the Contractor. The Contractor will have all of the obligations and the City will have all of the remedies that are specified in Section 11.
- 8.8.5 Subcontractor agrees to be bound to General Contractor and City in the same manner and to the same extent as General Contractor is bound to City under the Contract Documents. Subcontractor further agrees to include the same requirements and provisions of this agreement, including the indemnity and insurance requirements, with any Sub-subcontractor to the extent they apply to the scope of the Sub-subcontractor's work. A copy of the City's Contract Document Indemnity and Insurance provisions will be furnished to the Subcontractor upon request. The Contractor shall require all subcontractors to provide a valid certificate of insurance with the required endorsements included in the agreement prior to commencement of any work and General Contractor will provide proof of compliance to the City.
- 8.8.6 Coordination of Subcontract Work: The Contractor is responsible for scheduling the Work of subcontractors so as to avoid delay or injury to either Work or materials.
- 8.9 Insurance.
- 8.9.1 All required insurance shall be provided in the form of "occurrence"-type policies underwritten by admitted insurers in the State of California with a rating of A or better from the current year Best Rating Guide. All policies must be issued at the expense of the Contractor and must be maintained at the Contractor's expense throughout the performance of the Work.
- 8.9.2 The Contractor and any subcontractors engaged in performance of the Work must secure payment of workers compensation in accordance with California Labor Code Section 3700 and other applicable law. The Contractor must verify that all Subcontractors comply with this requirement.

8.9.3 Within ten (10) working days following notice of award the Contractor must submit to the City along with executed copies of all other documents specified in the Contract Check List certificates of insurance and endorsements evidencing that the Contractor has in effect and will maintain throughout the performance of the Work the following kinds and amounts of insurance:

8.9.3.1 Worker's Compensation Insurance. Workers Compensation and Employers Liability insurance as required by any applicable law, regulation or statute, including the provisions of Division IV of the Labor Code of the State of California, and any act or acts amending it. Worker's Compensation insurance must be for Statutory Limits and must cover the full liability of the Contractor. The Contractor's Employer's Liability Insurance must be in an amount no less than \$1,000,000.00 per occurrence. The insurance must be endorsed to waive all rights of subrogation against City and its officials, officers, employees, and volunteers for loss arising from or related to the work performed under this agreement.

8.9.3.2 Commercial General Liability and Automobile Liability Insurance. Coverage for liability because of Bodily Injury and Property Damage including, but not limited to the following coverage:

- Completed Operations and Products Liability
- Bodily Injury
- Personal Injury
- Broad Form Property Damage Liability
- Contractual Liability insuring the obligations assumed by the Contractor under the Contract Documents
- Automobile Liability, including owned, non-owned and hired automobiles
- Coverage for the XCU hazards of Explosion, Collapse and Underground Hazards

8.9.3.3 Commercial General Liability Self-Insured Retentions:

- All self-insured retentions (SIR) must be disclosed to City for approval and shall not reduce the limits of liability.
- Policies containing any self-insured retention (SIR) provision shall provide or be endorsed to provide that the SIR may be satisfied by either the named insured or the City.



- The City reserves the right to obtain a full certified copy of any insurance policy and endorsements. Failure to exercise this right shall not constitute a waiver of right to exercise later.

8.9.3.4 Commercial Umbrella Policy. The limits of insurance required in these Contract Documents may be satisfied by a combination of primary and umbrella or excess insurance. Any umbrella or excess insurance shall contain or be endorsed to contain a provision that such coverage shall also apply on a primary and non-contributory basis for the benefit of City (if agreed to in a written contract or agreement) before the City's own Insurance or self-insurance shall be called upon to protect it as a named insured.

8.9.3.5 Builders Risk. The Contractor must, at the Contractor's own expense, maintain a builder's risk fire insurance policy, special form including extended coverage and vandalism, and malicious mischief endorsements. The policy must name the City and the Contractor as insureds. Such insurance must be carried in the amount of 100% of the Contract Price. In the event of a partial or total destruction by fire of any or all of the Work at any time prior to the completion and acceptance thereof, the Contractor shall promptly reconstruct all Work so destroyed or injured at the Contractor's own cost and expense and at no cost to the City.

8.9.4 The Additional Insured coverage under the Contractor's policy shall be "primary and non-contributory" and will not seek contribution from the City's insurance or self-insurance and shall be at least as broad as CG 20 01 04 13.

8.9.5 The limits of the insurance required above will be at least:

Comprehensive General Liability

Bodily Injury Liability	\$2,000,000	each occurrence
	\$4,000,000	each aggregate
Property Damage Liability	\$2,000,000	each occurrence
	\$4,000,000	each aggregate

Comprehensive Automobile Liability

Bodily Injury Liability	\$2,000,000	each person
	\$2,000,000	each occurrence
Property Damage Liability	\$2,000,000	each occurrence

City of Fort Bragg  
 Project No. PWP-00127  
 Contract, Part 2  
 General Provisions

Builders Risk

issued for the value of the Contract Price

- 8.9.6 For each insurance policy required under the Agreement except for the required workers compensation insurance policy, the Contractor must provide endorsements that add the City, its officials, officers, employees, agents and volunteers as an additional insured (“Additional Insured”). Such endorsements must: provide that the insurance required to be furnished by the Contractor will be primary as regards the City, and that the City’s insurance will be excess of and not contribute to the insurance required to be furnished by the Contractor; that the City will receive 30 day written notice of any reduction or cancellation of such insurance required to be furnished by the Contractor; and include a severability of interest clause acceptable to the City. Said endorsement shall be at least as broad as Insurance Services Office form number CG2010 (Ed. 11/85).
- 8.9.7 It shall be a requirement under these Contract Documents that any available insurance proceeds broader than or in excess of the specified minimum insurance coverage requirements and/or limits shall be available to the Additional Insured. Furthermore, the requirements for coverage and limits shall be (1) the minimum coverage and limits specified in this Agreement; or (2) the broader coverage and maximum limits of coverage of any insurance policy or proceeds available to the named insured; whichever is greater.
- 8.9.8 Contractor shall maintain insurance as required by these Contract Documents to the fullest amount allowed by law and shall maintain insurance for a minimum of five years following the completion of this project. In the event contractor fails to obtain or maintain completed operations coverage as required by this Agreement, the City at its sole discretion may purchase the coverage required and the cost will be paid by Contractor.

#### 8.10 Indemnities.

- 8.10.1 The Contractor will take all responsibility for the Work, and will bear all losses and damages directly or indirectly resulting to the Contractor, any subcontractors engaged in performance of the Work, the City, its officials, officers, employees, agents, volunteers and consultants, and to third parties on account of the performance or character of the Work, unforeseen difficulties, accidents, or occurrences of other causes arising out of the Contractor’s execution of the Work or of any subcontractor engaged in performance of the Work. To the fullest extent permitted by law the Contractor will indemnify, defend and hold harmless the City, its officials, officers, employees, agents, volunteers and consultants from and against any or all loss, liability, expense, claims, costs

City of Fort Bragg  
Project No. PWP-00127  
Contract, Part 2  
General Provisions

(including costs of defense and consultants' costs), suits, and damages of every kind, nature and description (including, but not limited to, penalties resulting from exposure to hazards in violation of the California Labor Code and bodily injury or death) directly or indirectly arising from the Contractor's performance of the Work, failure to perform the Work, or condition of the Work that is caused in whole or in part by any act or omission of Contractor, its subcontractors, or anyone directly or indirectly employed by any of them, or anyone for whose acts any of them may be liable, resulting from any cause whatsoever, save for liability for any loss, damage, or expense arising out of the City's sole negligence or willful misconduct.

- 8.10.2 The Contractor will indemnify, defend and hold harmless the City, the City's officials, officers, employees, volunteers, agents and the Construction Manager and Architect for all liability on account of any patent rights, copyrights, trade names or other intellectual property rights that may apply to the Contractor's performance of the Work. The Contractor will pay all royalties or other charges as a result of intellectual property rights that may apply to methods, types of construction, processes, materials, or equipment used in the performance of the Work, and will furnish written assurance satisfactory to the City that any such charges have been paid.
- 8.10.3 The Contractor assumes all liability for any accident or accidents resulting to any person or property as a result of inadequate protective devices for the prevention of accidents in connection with the performance of the Work. The Contractor will indemnify, defend, and hold harmless the City and its officials, officers, employees, agents, volunteers and consultants from such liability.
- 8.10.4 Approval of the Contractor's certificates of insurance and/or endorsements does not relieve the Contractor of liability under this Section 8.9. The Contractor will defend, with legal counsel reasonably acceptable to the City, any action or actions filed in connection with any Claims and will pay all related costs and expenses, including attorney's fees incurred. The Contractor will promptly pay any judgment rendered against the City, its officials, officers, employees, agents, volunteers or consultants for any Claims. In the event the City, its officials, officers, employees, agents, volunteers or consultants is made a party to any action or proceeding filed or prosecuted against Contractor for any Claims, Contractor agrees to pay the City, its officials, officers, employees, agents, volunteers and consultants any and all costs and expenses incurred in such action or proceeding, including but not limited to, reasonable attorneys' fees.

- 8.10.5 Subject to the requirements of Section 5 of the General Provisions, the Contractor will indemnify, hold harmless and defend, with legal counsel reasonably acceptable to the City, the City and its officials, officers, employees, agents and volunteers from and against any and all claims related to damage to surface or underground facilities caused by the Contractor or any of the Contractor's privities or agents.
- 8.10.6 The Contractor will indemnify, hold harmless and defend, with legal counsel reasonably acceptable to the City, the City and its officials, officers, employees, agents and volunteers from and against any and all claims, including any fines or other penalties, related to failure of the Contractor and/or privities or agents of the Contractor to comply with the requirements of the General Permit, or to implement the Stormwater Pollution Prevention Plan ("SWPPP") in accordance with provision 12 of the Special Provisions. The City may withhold from amounts due or that may become due to the Contractor under this Contract amounts that equal or are estimated to equal the amount of claims, including fines, resulting from failure of the Contractor and/or privities or agents of the Contractor to comply with the requirements of the General Permit, or to implement the SWPPP in accordance with provision 12 of the Special Provisions.
- 8.10.7 In accordance with California Civil Code Section 2782(a), nothing in the Contract will be construed to indemnify the City for its sole negligence, willful misconduct, or for defects in design furnished by the City. By execution of the Contract Documents the Contractor acknowledges and agrees that the Contractor has read and understands the insurance and indemnity requirements of the Contract Documents, which are material elements of consideration.
- 8.10.8 The defense and indemnification obligations of these Contract Documents are undertaken in addition to, and shall not in any way be limited by, the insurance obligations contained in these Contract Documents.
- 8.10.9 Contractor/Subcontractor's responsibility for such defense and indemnity obligations shall survive the termination or completion of these Contract Documents for the full period of time allowed by law.
- 8.10.10 If Contractor fails to perform any of the foregoing defense and indemnity obligations, the City may defend itself and back-charge the Contractor for the City's costs and fees (including attorneys' and consultants' fees), and damages and withhold such sums from progress payments or other Contract monies which may become due.

- 8.11 Licenses/Permits. The Contractor must, without additional expense to the City, obtain all licenses, permits and other approvals required for the performance of the Work.
- 8.12 California Labor Code Requirements.
- 8.12.1 In accordance with California Labor Code Section 1771.1, this Project is subject to compliance monitoring and enforcement by the Department of Industrial Relations (DIR). The Contractor and subcontractors engaged in performance of the Work must comply with Labor Code Section 1771.1.
- 8.12.2 In accordance with California Labor Code Section 1810, eight (8) hours of labor in performance of the Work shall constitute a legal day's work under the Agreement.
- 8.12.3 In accordance with California Labor Code Section 1811, the time of service of any worker employed in performance of the Work is limited to eight hours during any one calendar day, and forty hours during any one calendar week, except in accordance with California Labor Code Section 1815, which provides that work in excess of eight hours during any one calendar day and forty hours during any one calendar week is permitted upon compensation for all hours worked in excess of eight hours during any one calendar day and forty hours during any one calendar week at not less than one-and-one-half times the basic rate of pay.
- 8.12.4 The Contractor and its subcontractors will forfeit as a penalty to the City \$25 for each worker employed in the performance of the Work for each calendar day during which the worker is required or permitted to work more than eight (8) hours in any one calendar day, or more than forty (40) hours in any one calendar week, in violation of the provisions of California Labor Code Section 1810 et seq.
- 8.12.5 In accordance with California Labor Code Section 1773.2, the City has determined the general prevailing wages in the locality in which the Work is to be performed for each craft or type of work needed to be as published by the State of California Department of Industrial Relations, Division of Labor Statistics and Research, a copy of which is on file in the Public Works Department and shall be made available on request. The Contractor and subcontractors engaged in the performance of the Work shall pay no less than these rates to all persons engaged in performance of the Work.
- 8.12.6 In accordance with California Labor Code Section 1775, the Contractor and any subcontractors engaged in performance of the Work must comply with Labor Code Section 1775 which establishes a

penalty of up to \$200 per day for each worker engaged in the performance of the Work that the Contractor or any subcontractor pays less than the specified prevailing wage. The amount of such penalty shall be determined by the Labor Commissioner. The Contractor or subcontractor shall pay the difference between the prevailing wage rates and the amount paid to each worker for each calendar day or portion thereof for which each worker was paid less than the prevailing wage rate. If a subcontractor worker engaged in performance of the Work is not paid the general prevailing per diem wages by the subcontractor, the Contractor is not liable for any penalties therefor unless the Contractor had knowledge of that failure or unless the Contractor fails to comply with all of the following requirements:

- 8.12.6.1 The contract executed between the Contractor and the subcontractor for the performance of part of the Work must include a copy of the provisions of California Labor Code Sections 1771, 1775, 1776, 1777.5, 1813, and 1815.
- 8.12.6.2 The Contractor must monitor payment of the specified general prevailing rate of per diem wages by the subcontractor by periodic review of the subcontractor's certified payroll records.
- 8.12.6.3 Upon becoming aware of a subcontractor's failure to pay the specified prevailing rate of wages, the Contractor must diligently take corrective action to halt or rectify the failure, including, but not limited to, retaining sufficient funds due the subcontractor for performance of the Work.
- 8.12.6.4 Prior to making final payment to the subcontractor, the Contractor must obtain an affidavit signed under penalty of perjury from the subcontractor that the subcontractor has paid the specified general prevailing rate of per diem wages to employees engaged in the performance of the Work and any amounts due pursuant to California Labor Code Section 1813.
- 8.12.7 In accordance with California Labor Code Section 1776, the Contractor and each subcontractor engaged in performance of the Work, must keep accurate payroll records showing the name, address, social security number, work classification, straight time and overtime hours worked each day and week, and the actual per diem wages paid to each journeyman, apprentice, worker, or other employee employed in performance of the Work. Each payroll record must contain or be verified by a written declaration that it is made under penalty of perjury, stating that the information contained in the

payroll record is true and correct and that the employer has complied with the requirements of Sections 1771, 1811, and 1815 for any work performed by the employer's employees on the public works project. The payroll records required pursuant to California Labor Code Section 1776 must be certified and must be available for inspection by the City and its authorized representatives, the Division of Labor Standards Enforcement, and the Division of Apprenticeship Standards of the Department of Industrial Relations and must otherwise be available for inspection in accordance with California Labor Code Section 1776.

8.12.8 In accordance with California Labor Code Section 1777.5, the Contractor, on behalf of the Contractor and any subcontractors engaged in performance of the Work, will be responsible for ensuring compliance with California Labor Code Section 1777.5 governing employment and payment of apprentices on public works contracts.

8.12.9 In case it becomes necessary for the Contractor or any subcontractor engaged in performance of the Work to employ on the Work any person in a trade or occupation (except executive, supervisory, administrative, clerical, or other non-manual workers as such) for which no minimum wage rate has been determined by the Director of the Department of Industrial Relations, the Contractor must pay the minimum rate of wages specified therein for the classification which most nearly corresponds to Work to be performed by that person. The minimum rate thus furnished will be applicable as a minimum for such trade or occupation from the time of the initial employment of the person affected and during the continuance of such employment.

8.13 Laws and Ordinances. The Contractor and all subcontractors engaged in the performance of the Work must conform to the following specific rules and regulations as well as all other laws, ordinances, rules and regulations that apply to the Work. Nothing in the Technical Specifications or Project Plans is to be construed to permit Work not conforming to these codes:

- National Electrical Safety Code, U. S. Department of Commerce
- National Board of Fire Underwriters' Regulations
- California Building Standards Code as adopted by the City
- California Mechanical Code as amended by applicable local ordinances for all construction work.
- California Administrative Code Titles 15, 19 and 24 (with California amendments), and Americans with Disabilities Act (ADA) accessibility guidelines, whichever is more stringent.
- Manual of Accident Prevention in Construction, latest edition, published by A.G.C. of America
- Industrial Accident Commission's Safety Orders, State of California

City of Fort Bragg  
Project No. PWP-00127  
Contract, Part 2  
General Provisions

- Regulations of the State Fire Marshall (Title 19, California Code of Regulation) and Applicable Local Fire Safety Codes
- Labor Code of the State of California - Division 2, Part 7, Public Works and Public Agencies
- Federal, state, and local air pollution control laws and regulations applicable to the Contractor and/or Work

8.14 Guaranty. The Contractor guarantees all of the Work for one year from the date the City accepts the Work. Upon receiving written notice of a need for repairs which are directly attributable to defective materials or workmanship the Contractor must make good any defects arising or discovered in any part of the Work by diligently commencing the necessary repairs within seven (7) days from the date of notice from the City. If the Contractor fails to make good any defects in the Work in accordance with this provision, in addition to any other available remedy under the contract or at law or equity, the City may make good or have made good such defects in the Work and deduct the cost from amounts that may be due or become due the Contractor, and/or call on the Contractor's maintenance bond for the cost of making good such defects and for the City's reasonable legal costs, if any, of recovering against the bond. The Contractor shall remain responsible for repairing any Work found to be defective regardless of when such defect is discovered by the City.

Where defective or rejected Work and any damage caused thereby has been corrected, removed, or replaced by the Contractor pursuant to this section, the guarantee period with respect to that Work shall be extended for an additional period of one year after such correction, removal, or replacement has been satisfactorily completed.

8.15 Safety.

8.15.1 In accordance with generally accepted construction practices and applicable law, the Contractor will be solely and completely responsible for conditions of the Work site, including safety of all persons and property during performance of the Work. This requirement will apply continuously and not be limited to normal working hours. For purposes of California Labor Code Section 6400 and related provisions of law, the Contractor and the Contractor's privities and any other entities engaged in the performance of the Work will be "employers" responsible for furnishing employment and a place of employment that is safe and healthful for the employees, if any, of such entities engaged in the performance of the Work. Neither the City nor its officials, officers, employees, agents, volunteers or consultants will be "employers" pursuant to California Labor Code Section 6400 and related provisions of law with respect to the Contractor, the Contractor's privities or other entities engaged in the performance of the Work. The Contractor agrees that neither the City,

City of Fort Bragg  
 Project No. PWP-00127  
 Contract, Part 2  
 General Provisions



the Construction Manager, the Architect, nor the Engineer will be responsible for having hazards corrected and/or removed at the Work site. The Contractor agrees that the City will not be responsible for taking steps to protect the Contractor's employees from such hazards, or for instructing the Contractor's employees to recognize such hazards or to avoid the associated dangers. The Contractor agrees with respect to the Work and the Work site, the Contractor will be responsible for not creating hazards and for having hazards corrected and/or removed, for taking appropriate, feasible steps to protect the Contractor's employees from such hazards and that the Contractor has instructed and/or will instruct its employees to recognize such hazards and how to avoid the associated dangers.

- 8.15.2 Review and inspection by the City, the Construction Manager, the Architect or Engineer, and/or other representatives of the City of the Contractor's performance of the Work will not constitute review of the adequacy of the Contractor's safety measures in, on, or near the Work site. Such reviews and inspections do not relieve the Contractor of any of the Contractor's obligations under the Contract Documents and applicable law to ensure that the Work site is maintained and the Work is performed in a safe manner.
  - 8.15.3 The Contractor will be solely responsible for the implementation and maintenance of safety programs to ensure that the Work site is maintained and the Work is performed in a safe manner in accordance with the Contract Documents and applicable law.
  - 8.15.4 Within ten (10) working days following notice of award the Contractor must submit to the City a copy of the Contractor's Safety Plan.
  - 8.15.5 The Contractor must furnish and place proper guards and systems for the prevention of accidents, including, but not limited to, those systems required pursuant to Title 8, Section 1670 et seq. of the California Code of Regulations concerning safety belts and nets. The Contractor must provide and maintain any other necessary systems or devices required to secure safety of life or property at the Work site in accordance with accepted standards of the industry and applicable law. The Contractor must maintain during all night hours sufficient lights to prevent accident or damage to life or property.
- 8.16 Assignment of Unfair Business Practice Claims. In accordance with California Public Contract Code Section 7103.5, the Contractor and any subcontractors offer and agree to assign to the City all rights, title, and interest in and to all causes of action the Contractor or any subcontractors may have under Section 4 of the Clayton Act (15 U.S.C. § 15) or under the Cartwright Act (Chapter 2 (commencing with § 16700) of Part 2 of Division 7 of the Business and Professions Code), arising from purchases of goods, services or materials

City of Fort Bragg  
Project No. PWP-00127  
Contract, Part 2  
General Provisions

pursuant to this contract. This assignment shall be made and become effective at the time the City tenders final payment to the Contractor, without further acknowledgement by the parties.

- 8.17 Contractor shall be responsible for properly notifying residents and property owners impacted by this project in accordance with City standards. Specific notification procedures vary with the type of work and shall be coordinated with the City before work begins. The City will furnish a list of impacted property owners.
- 8.18 Contractor shall use paper products and printing and writing paper that meets Federal Trade Commission recyclability standards as defined in 16 CFR 260.12.

## 9. MEASUREMENT AND PAYMENT

9.1 F.O.B. All shipments must be F.O.B. destination to the Work site and/or other sites indicated in the Contract Documents. The Contract Price is all-inclusive (including sales tax). There shall be no additional compensation paid for containers, packing, unpacking, drayage or insurance.

### 9.2 Payment

- 9.2.1 On or about the first day of each calendar month the Contractor will submit to the Construction Manager a verified application for payment and schedule of values supported by a statement showing all materials actually installed during the preceding month and the cost of labor actually expended in the performance of the Work. **Billing must be received on a monthly basis, at a minimum.** Unless otherwise provided in the Contract Documents, no allowances or payments will be made for material or equipment not placed at the Work site.
- 9.2.2 To be eligible for payment the Contractor's applications for payment must include certified payroll reports prepared in accordance with California Labor Code Section 1776 and the Agreement for each employee of the Contractor and any subcontractors engaged in the performance of the Work during the preceding months, applications for payment will not be processed without certified payroll reports.
- 9.2.3 In accordance with California Public Contract Code Section 20104.50, the City will review applications for payment as soon as practicable after receipt. Any application or part of an application that is determined to be improper will be returned to the Contractor as soon as practicable, but no later than seven (7) days after receipt by the City, along with a written description of the reasons why the application is improper. The Contractor's failure to submit a schedule in the time specified in Section 3.8, or its submission of a schedule to which the

City of Fort Bragg  
Project No. PWP-00127  
Contract, Part 2  
General Provisions

City has taken any uncorrected exception, shall serve as a basis for returning an application for payment in its entirety.

- 9.2.4 Unless the Contractor has elected to post securities in lieu of retention in accordance with California Public Contract Code Section 22300 and the Agreement, and the Contractor and the City have executed an escrow agreement in accordance with the Public Contract Code and the Agreement, the City will make progress payments to the Contractor in accordance with applicable law in the amount of ninety-five (95) percent of the value of the labor actually performed and the material incorporated in the Work as specified in Contractor's verified application for payment upon approval by the City's authorized representative(s). Payment of progress payments will not be construed as acceptance of the Work performed. If the Contractor has elected to post securities in lieu of retention in accordance with Public Contract Code Section 22300 and the Agreement and the Contractor and the City have executed an escrow agreement in accordance with the Public Contract Code and the Agreement, the City will make payments to the Contractor or the Contractor's escrow agent in accordance with such escrow agreement.
- 9.2.5 The City will pay the Contractor's final invoice in accordance with applicable law and this Section 9 following acceptance of the Work provided that:
  - 9.2.5.1 The Contractor has furnished evidence satisfactory to the City that all claims for labor and material have been paid, or the time for filing valid stop notices has passed and no stop notices have been filed, or all stop notices filed have been released by valid release or release bond acceptable to the City.
  - 9.2.5.2 No claim has been presented to the City by any person based upon any acts or omissions of the Contractor or any subcontractor engaged in the performance of the Work.
  - 9.2.5.3 No other claim or dispute exists under the Agreement or applicable law concerning payment of the Contractor's final invoice and/or release of the Agreement retention.
  - 9.2.5.4 The Contractor has filed with the City the Maintenance Bond provided in the Contract Documents with duly notarized signatures of an authorized representative of the Contractor and an attorney-in-fact of an admitted surety insurer acceptable to the City and such Maintenance Bond binds the Contractor as Principal and the Surety in accordance with its terms in the amount of 10% of the final Contract Price.

- 9.2.6 In accordance with California Public Contract Code Section 20104.50, if the City fails to make a progress payment within thirty (30) days of receipt of an undisputed, properly submitted application for payment, the City will pay the Contractor interest equivalent to the legal rate set forth in subdivision (a) of California Code of Civil Procedure Section 685.010. The number of days available to the City to make a payment without incurring an interest obligation pursuant to this provision and California Public Contract Code Section 20104.50 will be reduced by the number of days, if any, by which the City has delayed return of an application for payment beyond the seven day return requirement set forth in Section 9.2.5.
- 9.3 Non-Allowable Direct Charges. The following costs are not allowable direct charges under the Agreement. The following costs may only be paid under the Agreement, if at all, as part of any allowance for contractor overhead and/or profit established under the Agreement.
- 9.3.1 Labor costs in excess of applicable prevailing wages pursuant to the Agreement and applicable law, liability and workers compensation insurance, social security, retirement and unemployment insurance and other employee compensation and benefits pursuant to bona fide compensation plans in effect at the time specified for the opening of Project bids for contractor and subcontractor employees engaged in the performance of the Work or in excess of the labor costs specified in Section 4.5 of this Contract in the case of cost impacts involving items for which the Contract Documents do not specify prices and for which no lump sum amount has been approved by the City. However, in no event will allowable direct labor charges under the agreement include employee bonuses, employee vehicles or vehicle allowances, employee telephones or telephone allowances, or employee housing or housing allowances, whether or not such benefits are part of a bona fide compensation plan in effect at the time specified for the opening of Project bids.
- 9.3.2 Superintendent labor and clerical labor.
- 9.3.3 Bond premiums.
- 9.3.4 Insurance in excess of that required under Section 8.8.
- 9.3.5 Utility costs.
- 9.3.6 Work Site office expenses.
- 9.3.7 Home office expenses.
- 9.3.8 Permit or license costs.

9.4 Retention. The City or its agent may, in accordance with the Contract Documents and applicable law, withhold any payment of monies due or that may become due the Contractor because of:

- 9.4.1 Defective work not remedied or uncompleted work.
- 9.4.2 Claims filed or reasonable evidence indicating probable filing of claims.
- 9.4.3 Failure to properly pay subcontractors or to pay for material or labor.
- 9.4.4 Reasonable doubt that the Work can be completed for the balance then unpaid.
- 9.4.5 Damage to another contractor.
- 9.4.6 Damage to the City.
- 9.4.7 Damage to a third party.
- 9.4.8 Delay in the progress of the Work, which, in the City's judgment, is due to the failure of the Contractor to properly expedite the Work.
- 9.4.9 Liquidated damages or other charges that apply to the Contractor under the Agreement.
- 9.4.10 Any other lawful basis for withholding payment under the contract.

9.5 Securities in Lieu of Retention.

- 9.5.1 In accordance with Public Contract Code Section 22300, except where federal regulations or policies do not permit substitution of securities, the Contractor may substitute securities for any moneys withheld by the City to ensure performance of the Work. At the Contractor's request and expense, securities equivalent to the amount withheld will be deposited with the City, or with a state or federally chartered bank in California as the escrow agent, who will then pay those moneys to the Contractor under the terms of an Escrow for Security Deposit agreement. The Escrow for Security Deposit agreement is provided in the Contract Documents. Upon satisfactory completion of the Work, the securities will be returned to the Contractor.
- 9.5.2 Alternatively, at the Contractor's request and expense, the City will pay retentions earned directly to the escrow agent. At the Contractor's expense, the Contractor may direct investment of the payments into securities. Upon satisfactory completion of the Work, the Contractor will receive from the escrow agent all securities, interest, and payments received by the escrow agent from the City pursuant to this provision and the terms of the Escrow for Security Deposit agreement. The Contractor will, within 20 days of receipt of

payment, pay to each subcontractor the respective amount of interest earned, less costs of retention withheld from each Subcontractor, on monies withheld to ensure the Contractor's performance of the Work.

9.5.3 Securities eligible for investment in accordance with this provision include those listed in Government Code Section 16430, bank or savings and loan certificates of deposit, interest bearing demand deposit accounts, standby letters of credit, or any other security mutually agreed to by the Contractor and the City.

9.5.4 The Contractor will be the beneficial owner of any securities substituted for moneys withheld and will receive any interest thereon.

## 10. PROJECT ACCEPTANCE AND CLOSEOUT

10.1 Occupancy. The City reserves the right to occupy or use any part or parts or the entirety of the Work before the Work is fully performed. Subject to applicable law, exercising this right will in no way constitute acceptance of any part of the Work so occupied or used or acceptance of the entire Work, nor will such occupancy or use in any way affect the times when payments will become due the Contractor, nor will such occupancy or use in any way prejudice the City's rights under the Agreement, any Agreement bonds, or at law or equity. Occupancy or use shall not waive the City's rights to assess liquidated damages in accordance with Section 7 after the date of such occupancy or use.

10.2 Work Completion and Final Inspection. When the Contractor considers the Work is completed, the Contractor will submit written certification to the Construction Manager specifying that: the Contract Documents have been reviewed; the Work has been inspected for compliance with the Contract Documents; the Work has been completed in accordance with the Contract Documents; and that equipment and systems have been tested in the presence of the City's representative and are operational. The City and/or the City's authorized representatives will make an inspection to verify that the Work is complete and will notify the Contractor in writing of any incomplete or deficient Work. The Contractor will take immediate steps to remedy the stated deficiencies and give notice of correction to the Construction Manager. Upon receiving a notice of correction, the City or the City's authorized representatives will re-inspect the Work. The Contractor must correct all punch list items within 15 working days after the issuance of the punch list. Before acceptance of the Work the Contractor must submit: one set of the Project Record Drawings (As-Builts), and any equipment operating and maintenance instructions and data, warranties.

10.3 Work Acceptance.

10.3.1 All finished Work will be subject to inspection and acceptance or rejection by the City, the Construction Manager, and the Architect

City of Fort Bragg  
Project No. PWP-00127  
Contract, Part 2  
General Provisions

or Engineer and other government agencies having jurisdiction over the Work. Final acceptance of the Work will be at the discretion of the City.

- 10.3.2 The City will accept the Work in writing only when the Work has been completed to the City's reasonable satisfaction. Progress payments will in no way be construed as acceptance of any part of the Work.
- 10.3.3 In evaluating the Work, no allowance will be made for deviations from the Technical Specifications, Project Plans or other Contract Documents unless already approved in writing in accordance with the requirements of Section 4, above.
- 10.3.4 The fact that the Work and materials have been inspected from time to time and that progress payments have been made does not relieve the Contractor of the responsibility of replacing and making good any defective or omitted work or materials in accordance with the requirements of the Contract Documents.
- 10.3.5 None of the provisions of this section, including acceptance of the Project, final payment, or use or occupancy of the Project Site shall constitute acceptance of Work not done in accordance with the Contract Documents nor relieve Contractor of liability relating to the express guarantees or responsibility for faulty materials or workmanship. Nothing in this section or the Contract Documents shall be construed to limit, relieve, or release Contractor's, subcontractors', and materials suppliers' liability to the City for damages sustained as a result of latent defects in materials, equipment, or the Work caused by the Contractor, its agents, suppliers, employees, or Subcontractors.

## 11. REMEDIES AND DISPUTES

- 11.1 Failure to Correct Work. Within ten (10) working days of receiving written notice from the City describing Work that is defective or that is otherwise not in accordance with the requirements of the Agreement and/or applicable law and directing that such Work be corrected, the Contractor and/or the Contractor's sureties must give the City written notice of the intent of the Contractor and/or the Contractor's sureties to correct such Work and commence correction of such Work in accordance with the City's notice and the Agreement. If the Contractor and/or the Contractor's sureties do not give the City written notice of intent to correct such Work and commence correction of such Work within ten (10) working days of receipt of the City's notice, then the City may correct such work and/or have such work corrected for the account and at the expense of the Contractor and/or its sureties, and the Contractor and/or its sureties will be liable to the City for any resulting excess cost. The City may, in addition to all other remedies that the City may have under the Agreement

City of Fort Bragg  
Project No. PWP-00127  
Contract, Part 2  
General Provisions

and at law or equity, deduct any such excess cost of completing the Work from amounts that are due or that may become due the Contractor. Contractor shall not be entitled to an extension of the Time of Completion because of a delay in the performance of the Work attributable to the City's exercise of its rights under this section.

## 11.2 Termination for Cause

11.2.1 In accordance with California Public Contract Code Section 7105, in addition to all other available remedies that the City may have under the Agreement, and at law or equity, the City may terminate the Contractor's control of the Work for any material breach of the Contract, including, but not limited to the following:

11.2.1.1 If the Contractor or any of its subcontractors engaged in the performance of the Work fails to timely perform the Work and/or any of the Contractor's material obligations under the Contract Documents, including but not limited to submission of an acceptable schedule, that have accrued except for due to reasons beyond the control of the Contractor pursuant to the Contract Documents.

11.2.1.2 If the Contractor is adjudged bankrupt, or if it should make a general assignment for the benefit of creditors, or if a receiver should be appointed on account of its creditors.

11.2.1.3 If the Contractor or any of the subcontractors engaged in the performance of the Work persistently or repeatedly refuses or fails to supply enough properly skilled workmen or proper materials for the timely completion of the Work.

11.2.1.4 If the Contractor fails to make prompt payment to subcontractors engaged in the performance of the Work or for material or labor used in the performance of the Work in accordance with the Contract Documents and applicable law.

11.2.1.5 If the Contractor or any subcontractors engaged in the performance of the Work persistently disregards laws or ordinances applicable to the performance of the Work, or the instructions of the City, the Construction Manager, the Architect, or other authorized representatives of the City.

11.2.2 If the City intends to terminate the Contractor's control of the Work for any of the reasons specified in Sections 11.2.1.1 through 11.2.1.5, above, the City will immediately serve written notice to the Contractor and its sureties in accordance with the Contract Documents. Notice of the City's intent to terminate the Contractor's control of the Work will be given by registered or certified mail and specify the grounds for

City of Fort Bragg  
Project No. PWP-00127  
Contract, Part 2  
General Provisions



termination, the required cure and the time by which the cure must be effected. Upon receipt of notice of the City's intent to terminate the Contractor's control of the Work for any of the reasons specified in provisions 11.2.1.1 through 11.2.1.5, above, the Contractor will have ten (10) days from receipt of the notice or a longer time specified in the notice to cure its default. If the Contractor does not affect the required cure by the time specified in the notice, the City will issue a written notice of termination to the Contractor and its sureties by registered or certified mail. The notice of termination will specify: that upon receipt of the notice the Contractor's right to perform or complete the Work, including on behalf of the Contractor's sureties, is terminated; that the Contractor's sureties will have the right to take over and complete the Work and perform all of the Contractor's remaining obligations that have accrued under the Agreement; and that if the Contractor's sureties do not both give the City written notice of their intention to take over and perform the Agreement and commence completion of the Work and performance of all of the Contractor's remaining obligations that have accrued under the Agreement within ten (10) days after receipt of notice of termination that the City may declare the Contractor's sureties in default and take over the completion of the Work or have the Work completed for the account and at the expense of the Contractor and its sureties, and the Contractor and its sureties will be liable to the City for any resulting excess cost. The City may, in addition to all other available remedies that the City may have under the Contract Documents and at law or equity, deduct any such excess cost of completing the Work from amounts that are due or that may become due the Contractor.

- 11.2.3 Upon termination of the Contractor's control of the Work for any of the reasons specified in Sections 11.2.1.1 through 11.2.1.5, the Contractor will, if so directed by the City, immediately remove from the Work site any and all materials and personal property belonging to the Contractor which have not been incorporated in the Work and the Contractor and its sureties will be liable upon their bond for all damages caused the City by reason of the Contractor's failure to complete the Work.
- 11.2.4 Upon termination of the Contractor's control of the Work for any of the reasons specified in provisions 11.2.1.1 through 11.2.1.5, above, the City reserves the right to refuse tender of the Contractor by any surety to complete the Work.
- 11.2.5 If the City completes or has completed any portion of, or the whole of the Work, following termination of the Contractor's control of the Work for any of the reasons specified in Sections 11.2.1.1 through 11.2.1.5, above, the City will neither be liable for nor account to the Contractor

or the Contractor's sureties in any way for the time within which, or the manner in which such Work is performed, or for any changes made in such Work or for the money expended in satisfying claims and/or suits and/or other obligations in connection with completing the Work. If, following termination of the Contractor's control of the Work for any of the reasons specified in Sections 11.2.1.1 through 11.2.1.5, above, the unpaid balance of the Contract Price exceeds the expense of completing the Work, including compensation for additional legal, managerial and administrative services and all other amounts due for the completion of the Work and/or satisfaction of claims of the City and/or others arising out of the Agreement and any other charges that apply to the Contractor under the Agreement, the difference will be paid to the Contractor. If such expenses of completing the Work exceed the unpaid balance of the Contract Price, the Contractor or its sureties will pay the difference to the City.

- 11.2.6 If the Agreement or Contractor's control of the Work is terminated for any reason, Contractor waives all consequential damages resulting therefrom, including, but not limited to, the loss of any anticipated profit by the Contractor for the Work, the loss of profit on any potential or future jobs, and the loss of bonding capacity.
- 11.2.7 In accordance with California Government Code Section 4410, in the event a national emergency occurs, and public work being performed by contract is stopped, directly or indirectly, because of the freezing or diversion of materials, equipment or labor, as the result of an order or a proclamation of the President of the United States, or of an order of any federal authority, and the circumstances or conditions are such that it is impracticable within a reasonable time to proceed with a substantial portion of the work, then the City and the Contractor may, by written agreement, terminate the Agreement. In accordance with California Government Code Section 4411, such an agreement will include the terms and conditions of the termination of the contract and provision for the payment of compensation or money, if any, which either party will pay to the other or any other person, under the facts and circumstances in the case. Compensation to the Contractor will be determined on the basis of the reasonable value of the work done, including preparatory work. As an exception to the foregoing, in the case of any fully completed separate item or portion of the Work for which there is a separate contract price, the contract price shall control. The parties may in any other case adopt the contract price as the reasonable value of the work or any portion of the work done.
- 11.2.8 In the event a termination for cause is later determined to have been made wrongfully or without cause, then the termination shall be treated as a termination for convenience, and the Contractor shall

have no greater rights than it would have following a termination for convenience. Any contractor claim arising out of a termination for cause shall be made in accordance with this section.

### 11.3 Termination for Convenience.

- 11.3.1 The City may terminate performance of the Work under the Contract Documents in accordance with this clause in whole, or from time to time in part, whenever the City shall determine that termination is in the City's best interest. Termination shall be effected by the City delivering to the Contractor notice of termination specifying the extent to which performance of the Work under the Contract Documents is terminated, and the effective date of the termination.
- 11.3.2 Contractor shall comply strictly with the City's direction regarding the effective date of the termination, the extent of the termination, and shall stop work on the date and to the extent specified.
- 11.3.3 Contractor shall be entitled to a total payment on account of the Contract work so terminated measured by: (i) the actual cost to Contractor of Work actually performed, up to the date of the termination, with profit and overhead limited to twelve percent (12%) of actual cost of work performed, up to but not exceeding the actual contract value of the work completed as measured by the Schedule of Values and Progress Schedule; and (ii) offset by payments made and other contract credits. In connection with any such calculation, however, the City shall retain all rights under the Contract Documents including, without limitation, claims, indemnities, or setoffs.
- 11.3.4 Under no circumstances may Contractor recover legal costs of any nature, nor may Contractor recover costs incurred after the date of the termination.

### 11.4 Disputes.

The procedure set forth in California Public Contracts Code section 9204 (as summarized in Exhibit A attached hereto) shall apply to all "claims" by the Contractor on the City, as that term is defined in Section 9204. With respect to "claims" or any portion of a claim not resolved by way of the procedure set forth in Section 9204, the following procedure shall thereafter apply as follows:

- 11.4.1 In accordance with California Public Contract Code Section 20104.2, the following procedures apply to claims of \$375,000 or less between the Contractor and the City:
  - 11.4.1.1 The claim shall be in writing and include the documents necessary to substantiate the claim. Claims must be filed on or before the date of final payment. Nothing in this subdivision is intended to extend the time limit or supersede

City of Fort Bragg  
Project No. PWP-00127  
Contract, Part 2  
General Provisions

notice requirements otherwise provided by contract for the filing of claims.

- 11.4.1.2 For claims of less than fifty thousand dollars (\$50,000), the City shall respond in writing to any written claim within 45 days of receipt of the claim, or may request, in writing, within 30 days of receipt of the claim, any additional documentation supporting the claim or relating to defenses to the claim the City may have against the Contractor.
  - 11.4.1.2.1 If additional information is thereafter required, it shall be requested and provided pursuant to this subdivision, upon mutual agreement of the City and the Contractor.
  - 11.4.1.2.2 The City's written response to the claim, as further documented, shall be submitted to the Contractor within 15 days after receipt of the further documentation or within a period of time no greater than that taken by the Contractor in producing the additional information, whichever is greater.
- 11.4.1.3 For claims of over fifty thousand dollars (\$50,000) and less than or equal to three hundred seventy-five thousand dollars (\$375,000), the City shall respond in writing to all written claims within 60 days of receipt of the claim, or may request, in writing, within 30 days of receipt of the claim, any additional documentation supporting the claim or relating to defenses to the claim the City may have against the Contractor.
  - 11.4.1.3.1 If additional information is thereafter required, it shall be requested and provided pursuant to this subdivision, upon mutual agreement of the City and the Contractor.
  - 11.4.1.3.2 The City's written response to the claim, as further documented, shall be submitted to the Contractor within 30 days after receipt of the further documentation, or within a period of time no greater than that taken by the Contractor in producing the additional information or requested documentation, whichever is greater.
- 11.4.1.4 If the Contractor disputes the City's written response, or the City fails to respond within the time prescribed, the Contractor may so notify the City, in writing, either within 15

days of receipt of the City's response or within 15 days of the City's failure to respond within the time prescribed, respectively, and demand an informal conference to meet and confer for settlement of the issues in dispute. Upon a demand, the City shall schedule a meet and confer conference within 30 days for settlement of the dispute.

11.4.1.5 Following the meet and confer conference, if the claim or any portion remains in dispute, the Contractor may file a claim as provided in Chapter 1 (commencing with Section 900) and Chapter 2 (commencing with Section 910) of Part 3 of Division 3.6 of Title 1 of the Government Code. For purposes of those provisions, the running of the period of time within which a claim must be filed shall be tolled from the time the Contractor submits his or her written claim pursuant to subdivision (a) until the time that claim is denied as a result of the meet and confer process, including any period of time utilized by the meet and confer process.

11.4.1.6 This article does not apply to tort claims and nothing in this article is intended nor shall be construed to change the time periods for filing tort claims or actions specified by Chapter 1 (commencing with Section 900) and Chapter 2 (commencing with Section 910) of Part 3 of Division 3.6 of Title 1 of the Government Code.

11.4.2 In accordance with California Public Contract Code Section 20104.4, the following procedures apply to civil actions to resolve claims of \$375,000 or less between the City and the Contractor:

11.4.2.1 Within 60 days, but no earlier than 30 days, following the filing or responsive pleadings, the court shall submit the matter to non-binding mediation unless waived by mutual stipulation of both parties. The mediation process shall provide for the selection within 15 days by both parties of a disinterested third person as mediator, shall be commenced within 30 days of the submittal, and shall be concluded within 15 days from the commencement of the mediation unless a time requirement is extended upon a good cause showing to the court or by stipulation of both parties. If the parties fail to select a mediator within the 15-day period, any party may petition the court to appoint the mediator.

11.4.2.2 If the matter remains in dispute, the case shall be submitted to judicial arbitration pursuant to Chapter 2.5 (commencing with Section 1141.10) of Title 3 of Part 3 of the Code of Civil Procedure, notwithstanding Section 1141.11 of that code.

The Civil Discovery Act of 1986 (Article 3 (commencing with Section 2016) of Chapter 3 of Title 3 of Part 4 of the Code of Civil Procedure) shall apply to any proceeding brought under this subdivision consistent with the rules pertaining to judicial arbitration.

11.4.2.2.1 Notwithstanding any other provision of law, upon stipulation of the parties, arbitrators appointed for purposes of this article shall be experienced in construction law, and, upon stipulation of the parties, mediators and arbitrators shall be paid necessary and reasonable hourly rates of pay not to exceed their customary rate, and such fees and expenses shall be paid equally by the parties, except in the case of arbitration where the arbitrator, for good cause, determines a different division. In no event shall these fees or expenses be paid by state or county funds.

11.4.2.2.2 In addition to Chapter 2.5 (commencing with Section 1141.10) of Title 3 of Part 3 of the Code of Civil Procedure, any party who after receiving an arbitration award requests a trial de novo but does not obtain a more favorable judgment shall, in addition to payment of costs and fees under that chapter, pay the attorney's fees of the other party arising out of the trial de novo.

11.4.2.3 The court may, upon request by any party, order any witnesses to participate in the mediation or arbitration process.

11.4.3 In accordance with California Public Contract Code Section 20104.6:

11.4.3.1 The City shall not fail to pay money as to any portion of a claim which is undisputed except as otherwise provided in the contract.

11.4.3.2 In any suit filed under Public Contract Code Section 20104.4 concerning this contract, the City shall pay interest at the legal rate on any arbitration award or judgment. Such interest shall accrue from date the suit was filed.

## 11.5 Non-Waiver.

11.5.1 Either party's waiver of any breach or failure to enforce any of the terms, covenants, conditions or other provisions of the Contract Documents at any time shall not in any way affect, limit, modify or

waive that party's right thereafter to enforce or compel strict compliance with every term, covenant, condition or other provision hereof, any course of dealing or custom of the trade or oral representations notwithstanding.

- 11.5.2 Neither acceptance of the whole or any part of Work by City nor any verbal statements on behalf of City or its authorized agents or representatives shall operate as a waiver or modification of any provision of the Contract Documents, or of any power reserved to City herein nor any right to damages provided in the Contract Documents.

***\*\*\*THIS PAGE INTENTIONALLY LEFT BLANK\*\*\****

City of Fort Bragg  
Project No. PWP-00127  
Contract, Part 2  
General Provisions



CITY OF FORT BRAGG  
416 Franklin Street  
Fort Bragg, California 95437

**CONTRACT, PART 3**

**SPECIAL PROVISIONS**

12. SPECIAL PROVISIONS

12.1 Description of Work.

The Work in general consists of site preparation, material procurement and installation and other such items of work as are required to complete the project in accordance with this Contract, the Project Plans and Technical Specifications.

The estimate of the quantities of work to be done is approximate only, being as a basis for the comparison of bids, and the City does not expressly or by implication agree that the actual amount of work will correspond therewith, but reserves the right to increase or decrease the amount or any portion of the work as directed by the Construction Manager.

Incidental items of construction necessary to complete the whole Work in a satisfactory and acceptable manner as shown on the Project Plans and as provided for in the Technical Specifications and not specifically referred to in this section, will be understood to be furnished by the Contractor.

12.2 Construction Limitations.

The Contractor will be expected to conduct his or her operations in a manner that creates a minimum of damage to the natural vegetation and landscape. Ingress and egress must be via the existing driveways. Care must be exercised to avoid hazards that may cause injury to persons, animals or property either during working hours or after work hours, which will include dust control, backfilling trenches immediately following pipe laying and temporary fencing as required. Excavation made under this Contract must be backfilled before leaving the Work for the night.

The Contractor will be responsible for obtaining permission from the property owners for any construction outside of the Work site or easements as shown on the plans. Equipment will be restricted to the immediate area of construction, pipe trenches will be backfilled as soon as possible.

City of Fort Bragg  
Project No. PWP-00127  
Contract, Part 3  
Special Provisions

Receptacles for construction residue, including oil, cleaning fluids, and litter must be covered. Such residues must be disposed of in a proper manner.

Construction activity within the existing right-of-way must be scheduled to minimize traffic inconvenience and safety hazards to motorists, pedestrians and cyclists.

### 12.3 [SECTION REMOVED]

### 12.4 Maintaining Traffic and Pedestrian Operations.

The Contractor must conduct his or her operations so as to cause the least possible obstruction and inconvenience to public traffic. Unless otherwise approved by the Construction Manager, all traffic must be permitted to pass through the Work.

Due to the need to accommodate and minimize inconvenience to the public, unless expressly specified or approved in writing by the Construction Manager, no road closures will be permitted. Public vehicular and pedestrian traffic must be allowed to travel through the Work area with an absolute minimum of interruption or impedance unless otherwise provided for in the Special Provisions or approved in writing by the Construction Manager. The Contractor must make provisions for the safe passage of pedestrians around the area of Work at all times.

Residents affected by construction must be provided passage and access through the Work area to the maximum extent possible. Where existing driveways occur on the street, the Contractor must make provisions for the trench crossings at these points, either by means of backfill or by temporary bridges acceptable to the Construction Manager, so that the length of shut-down of any driveway is kept to a minimum. In addition, all driveways must be accessible at the end of each workday, and no driveway or property access may be closed for more than four (4) hours during the workday. Access to driveways, houses, and buildings along the road or street must be as convenient as possible and well maintained, and all temporary crossings must be maintained in good condition. To minimize the need for and complexity of detours, not more than one crossing or street intersection or road may be closed at any one time without the written approval of the Construction Manager.

The Contractor must provide multiple, advance written notices of closures to all affected property owners in a form approved by the Construction Manager.

Except as otherwise approved by the Construction Manager, the stockpiling or storing of material in City streets or rights of way shall be prohibited. Where this is unavoidable, all such materials must be piled or stored in a manner that will not obstruct sidewalks, driveways, or pedestrian crossings. Gutters and drainage channels must be kept clear and unobstructed at all times. All such materials shall be stored and handled in a manner that protects City streets, sidewalks, or other facilities from damage.

Where approved in advance by the Construction Manager, the Contractor must construct and maintain detours for the use of public traffic at his or her own expense. Failure or refusal of the Contractor to construct and maintain detours so approved at the proper time will be a material breach of the Contract subject to any and all remedies available pursuant to the Contract Documents and at law and equity. Such remedies include, but are not limited to, termination pursuant to Section 11.

Throughout performance of the Work, the Contractor must construct and adequately maintain suitable and safe crossings over trenches and such detours as are necessary to care for the public and private traffic at all times including Saturdays, Sundays and holidays.

The Contractor will be responsible for keeping all emergency services, including the Fort Bragg police and fire departments informed of obstructions to, or detours around any public or private roads caused by reasons of his or her operations.

The Contractor must comply with the State of California, Department of Transportation Manual of warning signs, lights, and devices for use and performance of work within the job site.

The fact that rain or other causes, either within or beyond the control of the Contractor, may force suspension or delay of the Work, shall in no way relieve the Contractor of his or her responsibility of maintaining traffic through the Project and providing local access as specified in this section. The Contractor must, at all times, keep on the job such materials, force and equipment as may be necessary to keep roads, streets and driveways within the Project open to traffic and in good repair and shall expedite the passage of such traffic, using such force and equipment as may be necessary.

Full compensation for conforming to the requirements of this section will be deemed included in the prices paid or the various Contract items of Work, and no additional allowances will be made therefor.

## 12.5 Public Safety.

The Contractor must at all times conduct the Work in accordance with Construction Safety Orders of the Division of Industrial Safety, State of California, to ensure the least possible obstruction to traffic and inconvenience to the general public, and adequate protection of persons and property in the vicinity of the Work.

No pedestrian or vehicle access way may be closed to the public without first obtaining permission of the Construction Manager.

Should the Contractor fail to provide public safety as specified or if, in the opinion of the Construction Manager, the warning devices furnished by the Contractor are not adequate, the City may place any warning lights or barricades or take any necessary action to protect or warn the public of any dangerous condition connected with the Contractor's operations, and the Contractor will be liable to the City for, and the City may deduct from amounts due or that may become due to the Contractor under the Contract, all costs incurred including, but not limited to, administrative costs.

Nothing in this section will be construed to impose tort liability on the City or Construction Manager.

Contractor acknowledges that, pursuant to the Americans with Disabilities Act ("ADA"), programs, services and other activities provided by a public entity to the public, whether directly or through a Contractor, must be accessible to the disabled public. Contractor shall provide the services specified in the Contract Documents in a manner that complies with the ADA and any and all other applicable federal, state and local disability rights legislation. Contractor agrees not to discriminate against disabled persons in the provision of services, benefits or activities provided under the Contract Documents and further agrees that any violation of this prohibition on the part of Contractor, its employees, agents or assigns shall constitute a material breach of the Contract Documents.

## 12.6 Protection of Existing Facilities and Property.

The Contractor must notify Underground Service Alert (USA) for marking the locations of existing underground facilities.

Subject to Section 5 of the General Provisions, the Contractor must take all necessary measures to avoid injury to existing surface and underground utility facilities in and near the Work site. Subject to Section 5 of the General Provisions, no error or omission of utility markouts will be construed to

relieve the Contractor from his responsibility to protect all underground pipes, conduits, cables or other structures affected by the Work.

The existing underground facilities in the area of Work may include telephone, television and electrical cables, gas mains, water mains, sewer pipe and drainage pipe. The various utility companies must be notified before trenching begins and at such other times as required to protect their facilities. Subject to Section 5 of the General Provisions, all underground facilities must be located and exposed ahead of trenching to prevent damage to the facilities, and to determine the depth and character of all facilities that cross or infringe on the trench prism. The Contractor must immediately notify the Construction Manager of any facilities found. If damage should occur to the existing facilities, the utility company and the City must be notified immediately and, subject to Section 5 of the General Provisions, repairs acceptable to the utility company must be made at the Contractor's expense.

The Project Plans show the underground utilities on the site of the construction insofar as they are known to the City. The drawings may not show facilities apparent from visual inspection of the site or service laterals or appurtenances, the existence of which can be inferred from the presence of other visible facilities such as buildings, meters, junction boxes, etc. on or adjacent to the construction site.

If in the performance of the Work an existing utility is encountered that is not shown on the Project Plans and is not apparent or inferable from visual inspection of the Project site, the Project Inspector must be notified immediately. The Construction Manager will determine, subject to Section 5 of the General Provisions, whether the Project Plans or Technical Specifications should be modified, or whether the existing utility should be relocated or whether the Contractor must work around the existing utility. Subject to Section 5 of the General Provisions, the Contractor must replace, at his or her own expense, in as good condition as they were prior to the start of construction, all existing improvements and surroundings damaged by his or her operation. Reconstruction of all existing improvements must conform to CITY OF FORT BRAGG Public Works Standard Specifications and Details under the direction of and subject to the acceptance by the Construction Manager.

Subject to Section 5 of the General Provisions, should the Contractor fail to take adequate measures to avoid injury or damage to the facilities described above, the City may take any actions necessary to protect such facilities from the Contractor's operations. Subject to Section 5 of the General Provisions, the City may withhold the cost of injury to existing surface and

City of Fort Bragg  
Project No. PWP-00127  
Contract, Part 3  
Special Provisions

underground utility facilities in and near the Work site from amounts due or that may become due the Contractor.

#### 12.7 Preconstruction Conference.

A pre-construction conference will be scheduled, at which time the Contractor must present his or her proposed work schedule in accordance with Section 3.8 of the General Provisions, information concerning offsite yards, Subcontractors, location of disposal and stock pile areas, and traffic control plans. All such schedules will be subject to the approval of the Construction Manager and the applicable agencies.

City will schedule and administer intermittent progress meetings throughout duration of work. City will determine the location and time for the meetings.

#### 12.8 Owner Notification.

The Contractor must notify all property owners and businesses affected by the Work at least 48 hours before Work is to begin. The notice must be in writing in the form of a door hanger, and must indicate the Contractor's name and phone number, type of work, day(s) and time when Work will occur. Notices must be reviewed in advance and approved by the Construction Manager.

#### 12.9 Emergency Service Providers Notifications.

The Contractor must furnish the name and phone number of a representative that can be contacted in the event of an emergency. Said information must be reported to the City Police Department dispatcher, and updated as required to provide 24-hour phone access.

#### 12.10 Clean up.

Attention is directed to Section 4-1.02 of the Caltrans Standard Specifications, which section is made a part of this Contract.

Before final inspection of the Work, the Contractor must clean the construction site and all ground occupied by him in connection with the Work, of all rubbish, excess material, falsework, temporary structures and equipment. All parts of the Work shall be left in a neat and presentable condition.

Nothing herein shall require the Contractor to remove warning, regulatory, and guide signs prior to formal acceptance by the Construction Manager.

City of Fort Bragg  
Project No. PWP-00127  
Contract, Part 3  
Special Provisions

#### 12.11 Payment.

Payment for all work and work requirements specified in these Special Provisions shall be considered as included in the Contract Price and no additional allowances shall be made therefore.

#### 12.12 Construction Staking.

Attention is directed to Section 3.9 of the General Provisions for information on Construction Staking.

#### 12.13 Materials Testing Allowance.

Attention is directed to Section 3.10 of the General Provisions for information on Materials Testing Allowance.

#### 12.14 Obstructions.

Attention is directed to Section 15, "Existing Highway Facilities," of the Caltrans Standard Specifications, which section is made a part of this Contract.

Attention is directed to the existence of overhead and underground power, telephone, and television cable poles, underground sewer mains and laterals, underground gas mains, and underground water mains and laterals within the area in which construction is to be performed.

Prior to starting the Work, the Contractor must (a minimum of 2 working days in advance) call Underground Service Alert (USA), toll free, at 811, and provide USA with all necessary data relative to the proposed work. USA will accept calls and process information to participating agencies who have underground facilities in the area between the hours of 7:30 a.m. and 5:00 p.m. daily, except Saturdays, Sundays, and holidays. Between the hours of 5:00 p.m. and 7:30 a.m. calls will be recorded and then processed after 7:30 a.m. For emergency situations, after hours and on Saturdays, Sundays and holidays, the Contractor shall contact the organization owning the affected facility. Upon notification, agencies having facilities in the area of the proposed excavation will mark their locations in the field using USA standard colors and codes to identify the facility.

The Contractor will be required to work around public and private utility facilities and other improvements that are to remain in place within the

construction area, and he will be held liable to the owners of such facilities for interference with service resulting from his operations.

#### 12.15 Hours of Work.

Unless otherwise specified herein, all construction activity, except for emergency situations, will be confined to Monday through Friday between the hours of 7:30 a.m. and 6:00 p.m., to minimize nuisances to local residents. Mufflers and/or baffles will be required on all construction equipment to control and minimize noise. The Contractor must comply with all applicable noise regulations in the City's Zoning Ordinance.

Saturdays, Sundays, holidays and overtime shall not be regarded as working days. Work shall not be allowed on non-working days without the expressed approval of the Construction Manager. The Contractor shall make a request for approval in writing with the stipulation (implied or expressed) that the Contractor shall pay for all overtime labor charges at the applicable hourly rate of the City or contract employee performing duties of inspector and/or resident engineer. All overtime labor charges shall be deducted from the final payment along with any liquidated damages.

Work necessary for the proper care and protection of work already performed or in case of emergency may be allowed without permission of the Construction Manager.

#### 12.16 Dust Control.

The Contractor must furnish all labor, equipment, and means required and carry out effective measures wherever and as often as necessary to prevent its operation from producing dust in amounts damaging to property, cultivated vegetation, or domestic animals, or causing a nuisance. The Contractor will be responsible for any damage resulting from any dust originating from the performance of the Work. The use of water resulting in mud on streets, sidewalks, or driveways, will not be permitted as a substitute for sweeping or other methods of dust control. The Contractor may not discharge smoke, dust, or any other air contaminants into the atmosphere in such quantity as will violate the regulations of any legally constituted authority.

Dust control must conform to the provisions in Sections 10-5, "Dust Control" and Section 18, "Dust Palliatives" of the Caltrans Standard Specifications, which section is made a part of this Contract.



#### 12.17 Water for Construction and Dust Control.

Unless otherwise provided, the Contractor will be responsible for applying to the City's Utility Department to establish utility accounts (at no charge) for all water necessary to perform the Work. The Contractor must comply with all City requirements for construction water, including provision of deposits and provision of backflow prevention devices. In accordance with State law, backflow prevention devices for construction water connections must be re-tested when relocated. The Contractor will be responsible for the cost of any re-testing.

The Contractor is prohibited from operating gate valves, fire hydrants, pumps or any other components of the City water system. The Contractor must contact the City's utilities staff, a minimum of twenty-four (24) hours in advance, to operate these or any other components on the City water system.

#### 12.18 Protection and Restoration of Vegetation.

Trees, lawns, shrubbery and vegetation that are not to be removed must be protected from damage or injury. Existing trees, shrubs, and other plants, that are not to be removed and are injured or damaged by reason of the Contractor's operations, must be replaced by the Contractor in accordance with the requirements in Section 20-3.01C, "Replacement," of the Caltrans Standard Specifications. Section 20-3.01C of the Caltrans Standard Specifications is made a part of this Contract.

When it is necessary to excavate adjacent to existing trees, shrubs, or hedges, the Contractor must use all possible care to avoid injury to the trees, shrubs, or hedges and their roots. No roots or limbs two inches (2") or larger in diameter may be cut without the express approval of the Construction Manager.

All roots two inches (2") in diameter and larger left in place must be wrapped with burlap to prevent scarring or excessive drying. When it is necessary to cut limbs and branches of trees to provide clearance for equipment used in construction, the Contractor must repair the damaged areas by properly painting with an emulsified asphalt type seal. All cuts through 1/2" or larger roots and limbs must be hand trimmed and cleanly cut before being repaired.

#### 12.19 Surplus Material.

All material removed or excavated during the course of construction will be surplus. All surplus material will be the property of the Contractor and be disposed of outside the right-of-way, unless the City elects to salvage certain

City of Fort Bragg  
Project No. PWP-00127  
Contract, Part 3  
Special Provisions

objects that are determined to be of historical interest. The City reserves the right of ownership of all objects that it elects to salvage, and the Contractor must protect such objects from subsequent damage until delivered unto the care of the owner.

#### 12.20 Cultural Resources.

In accordance with the National Historic Preservation Act of 1966 (16 U.S.C. 470), the following procedures are implemented to ensure historic preservation and fair compensation to the Contractor for delays attendant to the cultural resources investigation. The Contractor hereby agrees to comply with these procedures.

#### 12.21 Historical Finds.

In the event potential historical, architectural, archeological, or cultural resources (hereinafter called cultural resources) are discovered during subsurface excavations at the site of construction, the following procedures will apply:

1. The Contractor must immediately notify the Construction Manager and stop any Work that may jeopardize the find pending an investigation of its significance;
2. The Construction Manager will select a qualified archeologist (such as through the Northwest Information Center at Sonoma State University or other official contact) and wait for an archaeologist to complete an evaluation of significance before continuing Work in that area.
3. The Construction Manager will supply the Contractor with a "Stop Work Order" directing the Contractor to cease all portions of the Work that the Construction Manager determines may impact the find. The "Stop Work Order" will be effective until a qualified archaeologist assesses the value of the potential cultural resources. The "Stop Work Order" will contain the following:
  - a. A clear description of the Work to be suspended;
  - b. Any instructions regarding issuance of further orders by the Contractor for materials services;
  - c. Guidance as to action to be taken regarding Subcontractors;
  - d. Any direction to the Contractor to minimize costs; and
  - e. Estimated duration of the temporary suspension.
4. If the archaeologist determines the potential find is a bona fide cultural resource, the Construction Manager may extend the duration of the "Stop Work Order" in writing, and if so the "Stop Work Order" will

City of Fort Bragg  
Project No. PWP-00127  
Contract, Part 3  
Special Provisions

remain in effect and Work subject to the “Stop Work Order” may not resume until authorized by the Construction Manager.

#### 12.22 Cultural Resources Defined.

Possible indicators that a cultural resource has been found include, but are not limited to the following:

1. Prehistoric-era archaeological site indicators: obsidian tools, tool manufacture waste flakes, grinding and other implements, dwelling sites, animal or human bones, fossils, and/or locally darkened soil containing dietary debris such as bone fragments and shellfish remains;
2. Historic-era site indicators: ceramic, glass, and/or metal.

#### 12.23 Construction Manager’s Discretion.

Once possible cultural resources are found at the Work site, the Construction Manager may use discretion to continue the Work, regardless of the cultural resource find, if the Construction Manager determines that there are overriding considerations such as the instability of the excavation site, the existence of adverse weather or other conditions that would preclude leaving the site exposed, or if the site would be unsafe to workers who would retrieve cultural resource items from therein.



CITY OF FORT BRAGG  
416 Franklin Street  
Fort Bragg, California 95437

**CONSTRUCTION PERFORMANCE BOND**

**(Note: The successful bidder must use this form. Use of any other bond form may prevent a contract from forming and/or result in forfeiture of the successful bidder's bid bond.)**

THIS CONSTRUCTION PERFORMANCE BOND (Bond), dated \_\_\_\_\_, is in the amount of \_\_\_\_\_ (Penal Sum), which is 100% of the Contract Sum and is entered into by and between the parties listed below to ensure the faithful performance of the Contract identified below. This Bond consists of this page and the Bond Terms and Conditions, Paragraphs 1 through 14 attached to this page. Any singular reference to \_\_\_\_\_ (Contractor), \_\_\_\_\_ (Surety), City of Fort Bragg (City), or other party shall be considered plural where applicable.

CONTRACTOR:

SURETY:

\_\_\_\_\_  
Name of Contractor

\_\_\_\_\_  
Name of Surety

\_\_\_\_\_  
Address

\_\_\_\_\_  
Principal Place of Business

\_\_\_\_\_  
City/State/Zip

\_\_\_\_\_  
City/State/Zip

CONSTRUCTION CONTRACT:

Agreement for the *Bollard and Streetlights Project* (Project) located at in the Central Business District, Fort Bragg, California, dated \_\_\_\_\_, in the amount of \_\_\_\_\_.

CONTRACTOR AS PRINCIPAL

SURETY

Company: (Corp. Seal)

Company: (Corp. Seal)

Signature: \_\_\_\_\_

Signature: \_\_\_\_\_

Name: \_\_\_\_\_

Name: \_\_\_\_\_

Title: \_\_\_\_\_

Title: \_\_\_\_\_

City of Fort Bragg  
Project No. PWP-00127  
Construction Performance Bond

## BOND TERMS AND CONDITIONS

1. Contractor and Surety, jointly and severally, bind themselves, their heirs, executors, administrators, successors and assigns to the City and the State of California for the complete and proper performance of the Construction Contract, which is incorporated herein by reference.
2. If Contractor completely and properly performs all of its obligations under the Construction Contract, Surety and Contractor shall have no obligation under this Bond.
3. If there is no City Default, Surety's obligation under this Bond shall arise after:
  - 3.1 City provides Surety with written notice that City has declared a Contractor Default under the Construction Contract pursuant to the terms of the Construction Contract; and
  - 3.2 City has agreed to pay the Balance of the Contract Sum:
    - 3.2.1 To Surety in accordance with the terms of this Bond and the Construction Contract; or
    - 3.2.2 To a Contractor selected to perform the Construction Contract in accordance with the terms of this Bond and the Construction Contract.
4. When City has satisfied the conditions of Paragraph 3 above, Surety shall promptly (within 40 Days) and at Surety's expense elect to take one of the following actions:
  - 4.1 Arrange for Contractor, with consent of City, to perform and complete the Construction Contract (but City may withhold consent, in which case the Surety must elect an option described in Paragraphs 4.2, 4.3 or 4.4 below); or
  - 4.2 Undertake to perform and complete the Construction Contract itself, through its agents or through independent contractors or Construction entities; provided, that Surety may not select Contractor as its agent or independent contractor or Contractor without City's consent; or
  - 4.3 Undertake to perform and complete the Construction Contract by obtaining bids from qualified contractors or Construction entities acceptable to City for a contract for performance and completion of the Construction Contract and, upon determination by City of the lowest responsive and responsible Bidder, arrange for a contract to be prepared for execution by City and the contractor or Contractor selected with City's concurrence, to be secured with performance and payment bonds executed by a qualified surety

equivalent to the bonds issued on the Construction Contract; and, if Surety's obligations defined in Paragraph 6 below, exceed the Balance of the Contract Sum, then Surety shall pay to City the amount of such excess; or

- 4.4 Waive its right to perform and complete, arrange for completion, or obtain a new contractor or Contractor, and with reasonable promptness under the circumstances and, after investigation and consultation with City, determine in good faith its monetary obligation to City under Paragraph 6 below, for the performance and completion of the Construction Contract and, as soon as practicable after the amount is determined, tender payment therefor to City with full explanation of the payment's calculation. If City accepts Surety's tender under this Paragraph 4.4, City may still hold Surety liable for future damages then unknown or unliquidated resulting from the Contractor Default, as agreed by City and Surety at the time of tender. If City disputes the amount of Surety's tender under this Paragraph 4.4, City may exercise all remedies available to it at law to enforce Surety's liability under Paragraphs 6 and 7 below.
5. At all times City shall be entitled to enforce any remedy available to City at law or under the Construction Contract including, without limitation, and by way of example only, rights to perform work, protect Work, mitigate damages, advance critical Work to mitigate schedule delay, and coordinate Work with other consultants or contractors.
6. If Surety elects to act under Paragraphs 4.1, 4.2 or 4.3 above, within the time period provided in Paragraph 4, above, and complies with its obligations under this Bond, Surety's obligations under this Bond are commensurate with Contractor's Construction Contract obligations. Surety's obligations include, but are not limited to:
  - 6.1 Contractor's obligations to complete the Construction Contract and correct Defective Work;
  - 6.2 Contractor's obligations to pay liquidated damages; and
  - 6.3 To the extent otherwise required of Contractor under the Construction Contract, Contractor's obligations to pay additional legal, design professional, and other costs not included within liquidated damages resulting from Contractor Default (but excluding attorney's fees incurred to enforce this Bond).

7. If Surety does not elect to act under Paragraphs 4.1, 4.2, 4.3, or 4.4, above, within the time period provided in Paragraph 4, above, or comply with its obligations under this Bond, then Surety shall be deemed to be in default on this Bond ten Days after receipt of an additional written notice from City to Surety demanding that Surety perform its obligations under this Bond. Such Surety default shall be independent of the Contractor Default. To the extent Surety's independent default causes City to suffer damages including, but not limited to, delay damages, which are different from, or in addition to (but not duplicative of) damages which City is entitled to receive under the Construction Contract, Surety shall also be liable for such damages. In the event any Surety obligation following its independent default is inconsistent or conflicts with California Civil Code Section 2809, or any other law which either prohibits, restricts, limits or modifies in any way any obligation of a surety which is larger in amount or in any other respect more burdensome than that of the principal, Surety hereby waives the provisions of such laws to that extent.
8. If Surety elects to act under Paragraphs 4.1, 4.2, 4.3 or 4.4 above, within the time period provided in Paragraph 4, above, and complies with all obligations under this Bond, Surety's monetary obligation under this Bond is limited to the Penal Sum.
9. No right of action shall accrue on this Bond to any person or entity other than City or its successors or assigns.
10. Surety hereby waives notice of any change, alteration or addition to the Construction Contract or to related subcontracts, design agreements, purchase orders and other obligations, including changes of time, and of any City action in accordance with Paragraph 5 above. Surety consents to all terms of the Construction Contract, including provisions on changes to the Contract. No extension of time, change, alteration, Modification, deletion, or addition to the Contract Documents, or of the Work (including services) required thereunder, or any City action in accordance with Paragraph 5 above shall release or exonerate Surety on this Bond or in any way affect the obligations of Surety on this Bond, unless such action is an City Default.
11. Any proceeding, legal or equitable, under this Bond shall be instituted in any court of competent jurisdiction where a proceeding is pending between City and Contractor regarding the Construction Contract, or in the Superior Court of the County of Mendocino, California, or in a court of competent jurisdiction in the location in which the Work is located. Communications from City to Surety under Paragraph 3.1 above shall be deemed to include the necessary agreements under Paragraph 3.2 above unless expressly stated otherwise.
12. All notices to Surety or Contractor shall be mailed or delivered (at the address set forth on the signature page of this Bond), and all notices to City shall be mailed or delivered as provided in the Construction Contract. Actual receipt of notice by

City of Fort Bragg  
Project No. PWP-00127  
Construction Performance Bond



Surety, City or Contractor, however accomplished, shall be sufficient compliance as of the date received at the foregoing addresses.

13. Any provision in this Bond conflicting with any statutory or regulatory requirement shall be deemed deleted herefrom and provisions conforming to such statutory requirement shall be deemed incorporated herein.

14. Definitions

14.1 Balance of the Contract Sum: The total amount payable by City to Contractor pursuant to the terms of the Construction Contract after all proper adjustments have been made under the Construction Contract, for example, deductions for progress payments made, and increases/decreases for approved Modifications to the Construction Contract.

14.2 Construction Contract: The agreement between City and Contractor identified on the signature page of this Bond, including all Contract Documents and changes thereto.

14.3 Contractor Default: Material failure of Contractor, which has neither been remedied nor waived, to perform or otherwise to comply with the terms of the Construction Contract, limited to "default" or any other condition allowing a termination for cause as provided in the Construction Contract.

14.4 City Default: Material failure of City, which has neither been remedied nor waived, to pay Contractor progress payments due under the Construction Contract or to perform other material terms of the Construction Contract, if such failure is the cause of the asserted Contractor Default and is sufficient to justify Contractor termination of the Construction Contract.

**END OF DOCUMENT**

***\*\*\*THIS PAGE INTENTIONALLY LEFT BLANK\*\****

City of Fort Bragg  
Project No. PWP-00127  
Construction Performance Bond

CITY OF FORT BRAGG  
416 Franklin Street  
Fort Bragg, California 95437

**CONSTRUCTION LABOR AND MATERIAL PAYMENT BOND**

**(Note: The successful bidder must use this form. Use of any other bond form may prevent a contract from forming and/or result in forfeiture of the successful bidder's bid bond.)**

KNOW ALL PERSONS BY THESE PRESENTS:

1.01 WHEREAS, the City of Fort Bragg, 416 N. Franklin Street, Fort Bragg, California 95437 (City) has awarded a Contract to \_\_\_\_\_ as Principal, dated the \_\_\_\_\_ day of \_\_\_\_\_, 20\_\_\_\_ (the Contract), titled **THE BOLLARD AND STREETLIGHTS PROJECT** in the amount of \$\_\_\_\_\_, which Contract is by this reference made a part hereof, for the work of the following Contract:

\_\_\_\_\_  
\_\_\_\_\_  
\_\_\_\_\_

1.02 WHEREAS, Principal is required to furnish a bond in connection with the Contract to secure the payment of claims of laborers, mechanics, material suppliers, and other persons as provided by law;

1.03 NOW, THEREFORE, we, the undersigned Principal and \_\_\_\_\_, as Surety, are held and firmly bound unto City in the sum of 100% OF THE CONTRACT PRICE (\$\_\_\_\_\_), for which payment well and truly to be made we bind ourselves, our heirs, executors, administrators, successors, and assigns, jointly and severally, firmly by these presents.

1.04 THE CONDITION OF THIS OBLIGATION IS SUCH, that if Principal, or its executors, administrators, successors, or assigns approved by City, or its subcontractors shall fail to pay any of the persons named in California Civil Code Section 9100, or amounts due under the State of California Unemployment Insurance Code with respect to work or labor performed under the Contract, or for any amounts required to be deducted, withheld, and paid over to the State of California Employment Development Department from the wages of employees of Principal and subcontractors pursuant to Section 13020 of the State of California Unemployment Insurance Code with respect to such work and labor, that Surety will pay for the same in an amount not exceeding the sum specified in this bond,

City of Fort Bragg  
Project No. PWP-00127  
Construction Labor & Material Payment Bond

plus reasonable attorneys' fees, otherwise the above obligation shall become and be null and void.

- 1.05 This bond shall inure to the benefit of any of the persons named in California Civil Code Section 9100, as to give a right of action to such persons or their assigns in any suit brought upon this bond. The intent of this bond is to comply with the California Mechanic's Lien Law.
- 1.06 Surety, for value received, hereby expressly agrees that no extension of time, change, modification, alteration, or addition to the undertakings, covenants, terms, conditions, and agreements of the Contract, or to the work to be performed thereunder, shall in any way affect the obligation of this bond; and it does hereby waive notice of any such extension of time, change, modification, alteration, or addition to the undertakings, covenants, terms, conditions, and agreements of the Contract, or to the work to be performed thereunder.
- 1.07 Surety's obligations hereunder are independent of the obligations of any other surety for the payment of claims of laborers, mechanics, material suppliers, and other persons in connection with Contract; and suit may be brought against Surety and such other sureties, jointly and severally, or against any one or more of them, or against less than all of them without impairing City's rights against the other.
- 1.08 Correspondence or claims relating to this bond shall be sent to Surety at the address set forth below.

IN WITNESS WHEREOF, we have hereunto set our hands this \_\_\_\_\_day of \_\_\_\_\_, \_\_\_\_\_.

**CONTRACTOR AS PRINCIPAL**

**SURETY**

Company: (Corp. Seal)

Company: (Corp. Seal)

\_\_\_\_\_  
Signature

\_\_\_\_\_  
Signature

\_\_\_\_\_  
Name

\_\_\_\_\_  
Name

\_\_\_\_\_  
Title

\_\_\_\_\_  
Title

\_\_\_\_\_  
Street Address

\_\_\_\_\_  
Street Address

\_\_\_\_\_  
City, State, Zip Code

\_\_\_\_\_  
City, State, Zip Code

**END OF DOCUMENT**

City of Fort Bragg  
Project No. PWP-00127  
Construction Labor & Material Payment Bond

FORT BRAGG  
416 Franklin Street  
Fort Bragg, California 95437

**MAINTENANCE BOND**

**(Note: The successful bidder must use this form. Use of any other bond form may prevent a contract from forming and/or result in forfeiture of the successful bidder's bid bond.)**

KNOW ALL MEN BY THESE PRESENTS:

WHEREAS the City Council of the CITY OF FORT BRAGG has awarded to \_\_\_\_\_, (designated as the "PRINCIPAL") a contract for the **Bollard and Streetlights Project, Project No. PWP-00127**, which contract and all of the contract documents as defined therein (designated as the "Contract") are hereby made a part hereof; and

WHEREAS, the PRINCIPAL is required under the terms of the Contract to furnish a bond for the correction of any defects due to defective materials or workmanship in the work performed under the Contract.

NOW, THEREFORE, we the PRINCIPAL and the undersigned \_\_\_\_\_, as surety (designated as "SURETY"), an admitted surety insurer authorized to do business in the State of California, are held and firmly bound unto the CITY OF FORT BRAGG, (designated as the "OBLIGEE"), in the penal sum of \_\_\_\_\_ Dollars (\$\_\_\_\_\_), lawful money of the United States, being a sum not less than ten percent (10%) of the final Contract price, for the payment of which sum well and truly to be made, we bind ourselves, our heirs, executors, administrators, successors, and assigns jointly and severally, firmly by these presents.

THE CONDITIONS OF THIS OBLIGATION ARE SUCH that if, during a maintenance period of one (1) year from the date of acceptance by the OBLIGEE of the contracted work, the PRINCIPAL upon receiving written notice of a need for repairs which are directly attributable to defective materials or workmanship, shall diligently take the necessary steps to correct said defects within seven (7) days from the date of said notice, then this obligation shall be null and void; otherwise it shall remain in full force and effect.

If any action shall be brought by the OBLIGEE upon this bond, a reasonable attorney's fee, to be fixed by the Court, shall be and become a part of OBLIGEE's judgment in any such action.

No right of action shall accrue on this bond to, or for the use of, any person or corporation other than the OBLIGEE named herein or the heirs, executors, administrator or successor of the OBLIGEE.

IN WITNESS WHEREOF, the above bound parties have executed this instrument under their seals this \_\_\_\_\_ day of \_\_\_\_\_, 20\_\_\_\_ the name and corporate seals

City of Fort Bragg  
Project No. PWP-00127  
Construction Labor & Material Payment Bond

of each corporate party being hereto affixed and these presents duly signed by its undersigned representative, pursuant to authority of its governing body.

(Corporate Seal)

PRINCIPAL

By: \_\_\_\_\_

(Acknowledgement)

Title: \_\_\_\_\_

(Corporate Seal)

SURETY

By: \_\_\_\_\_

(Attorney-in-fact)

(Acknowledgement)

Title: \_\_\_\_\_

*(NOTE TO SURETY COMPANY: A certified copy of unrevoked resolution of authority for the attorney-in-fact must be submitted with and attached to the executed bid bond.)*

**END OF DOCUMENT**

## EXHIBIT A

### CLAIMS PROCEDURE

#### SUMMARY OF PUBLIC CONTRACT CODE § 9204

The following procedure will apply to any claims by the Contractor on the City:

A “claim” is a separate demand on the City by a contractor on a public works project and sent by registered mail or certified mail with return receipt requested, for one or more of the following:

- A time extension, including relief from penalties for delay
- Payment by the City of money damages under the terms of the contract
- Payment of an amount that is disputed by the City

#### Initial Review

The claim must be supported by appropriate documentation. The City has 45 days within which to review the claim and provide the contractor with a written statement identifying the disputed and undisputed portions of the claim. If the City does not issue a written statement, the claim is deemed rejected in its entirety. The City will pay any undisputed portion of the claim within 60 days of issuing the statement.

#### Meet & Confer

If the contractor disputes the City’s written response, or if the City does not issue one, the contractor may request in writing an informal conference to meet and confer for possible settlement of the claim. The City will schedule the meet and confer conference within 30 days of this request and provide a written statement identifying the remaining disputed and undisputed portions of the claim within 10 business days of the meet and confer. The City will pay the undisputed portion within 60 days of issuing this statement.

#### Mediation

With respect to any disputed portion remaining after the meet and confer, the City and contractor will submit the matter to nonbinding mediation, agree to a mediator within 10 business days after issuing the written statement, and share mediation costs equally. If mediation is unsuccessful, then the terms of the public works agreement and applicable law will govern resolution of the dispute.

#### Miscellaneous Provisions

Amounts not paid by the City in a timely manner bear interest at 7% per annum. Subcontractors may submit claims via this procedure through the general contractor. The City and contractor may waive the requirement to mediate, but cannot otherwise waive these claim procedures.







# VOLUME 3



**Bollard & Street Light  
Project  
PWP-00127**



**CITY OF FORT BRAGG, CALIFORNIA**  
**DEPARTMENT OF PUBLIC WORKS**

**BOLLARD & STREET LIGHT PROJECT**

The Technical Specifications contained herein have been prepared by or under the direction of the following Registered Persons:

*Aaron Brusatori*

---

Registered Professional Engineer (Civil)







## TECHNICAL SPECIFICATIONS

### BOLLARD AND STREET LIGHT PROJECT

#### TABLE OF CONTENTS

TABLE OF CONTENTS.....	1
GENERAL.....	1
SUBMITTALS .....	1
REPAINT STREET LIGHT.....	2
REPLACE EXISTING DAMAGED OR MISSING LIGHT POLE.....	5
INSTALL BOLLARD .....	9
BOLLARD STORAGE RACK.....	11
APPENDIX A.....	13

#### GENERAL

The Contractor shall furnish all labor, equipment, mobilization, and traffic control necessary for the repainting of street lights, replacement of missing lights, and installing bollards and bollard racks shown on the Project Plans. Light poles and fixtures shall be thoroughly cleaned, primed, and painted in accordance with industry standards, and as specified in this document. The worksite shall be secured before, during, and after all work being performed. All pedestrian and vehicular traffic within the worksite or adjacent areas must be thoroughly protected from injury or damage caused by paint, solvents, or the processes of cleaning and painting. Additional protection shall be provided for all public and private property within the worksite or adjacent areas including landscape features, infrastructure, structures, and other surfaces but within the work zone. All surfaces shall be cleaned and prepared in accordance with industry standards prior to painting and bollard installation. The worksite and adjacent areas must be completely restored to the general condition and appearance as was before the work began.

#### SUBMITTALS

The Contractor shall submit shop drawings, product data and samples as required for conformance with the Project Plans and Technical Specifications. Submittals shall conform to the City Standard Specifications Section 1-1.08, "Shop Drawings" and Volume 1 Submittals Section of Contract Provisions. At a minimum, the Contractor shall submit the following for review and approval by the City:

City of Fort Bragg  
PWP-00127  
Technical Specifications

Item	Submitted	Approved	Notes
Pre-Construction Documentation			
Traffic Control Plan			
Pollution Prevention Best Management Practices			
Project Schedule			
Bollard & Post			
Paint Coating Manufacture			
Paint Color Sample of Coating			
Street light poles Holophane "Charleston" series			
Bollard Storage Rack			
Caltrans Encroachment Permit			
Door Hanger Notices to Property Owners			

## REPAINT STREET LIGHT

### Submittals

Upon the request of the City, the Contractor shall provide the coating manufacturer's name, product data for each coating, including generic description, complete technical data, surface preparation, and application instructions. The Contractor shall procure coatings and coating application accessories from a single coating manufacturer. After contract award, samples of the color specified shall be submitted for approval.

### Quality Assurance

#### Coating Manufacturer's Qualifications

The coating manufacturer shall be specialized in the manufacture of coatings with a minimum of ten (10) years of experience.

The coatings manufacturer shall be able to demonstrate successful performance on comparable projects.

#### Applicator's Qualifications

The contractor shall be experienced in the application of specified coatings for a minimum of five (5) years on projects of similar size and complexity and should be considered as an Industrial Coatings contractor.

The contractor shall employ persons trained for the application of the specified

coatings.

## **Environmental Requirements**

### **Weather**

The contractor shall prepare surfaces and apply and cure coatings within the air and surface temperature range in accordance with the manufacturer's instructions.

The contractor shall maintain surface temperatures a minimum of five (5) degrees F (three (3) degrees C) above dew point at the time of final surface preparation, material mixing, and application.

The contractor shall prepare surfaces and apply and cure coatings within the relative humidity range in accordance with the coating manufacturer's instructions.

The contractor shall not prepare surfaces or apply coatings in rain, snow, fog, or mist.

The contractor shall not spray coatings if wind velocity is above the coating manufacturer's limit.

### **Dust and Contaminants**

The contractor shall schedule coating work to avoid excessive dust and airborne contaminants, and shall take the necessary steps to protect work areas from excessive dust and airborne contaminants during the coating application and curing process.

### **Protection of Surfaces Not Scheduled to be Coated**

The contractor shall protect surrounding areas and surfaces that are not scheduled to be coated from damage during surface preparation and the application of coatings.

The contractor shall immediately remove coatings that fall on surrounding areas and surfaces that are not scheduled to be coated.

### **Surface Preparation**

#### **Cleaning**

All surfaces to be painted shall be scraped or wire brushed to remove all flaking or loose paint. Wire wheels and/or cup brush grinder attachments may be used. All welds should be inspected and any failed welds should be reported prior to painting. All metal surfaces shall be thoroughly cleaned of oil, grease, soil, rust scale, and all other foreign substances. Oil and grease may be removed with clean rags saturated in mineral spirits. After cleaning metal surfaces and before applying paint, the contractor shall clean the pole and the paved area surrounding the base of all sand, dust, or other foreign matter in order to prevent such materials from being blown on to the freshly painted surface. All surfaces that are not to be painted (glass/plastic panels, attached signs, light pole inventory number, hand-hole screws, etc.) shall be protected from paint and painting operations.

City of Fort Bragg  
PWP-00127  
Technical Specifications

## **Rust Treatment**

Any areas showing signs of oxidization shall be thoroughly wire brushed and treated with a rust converter that has been approved by the project manager. This process is necessary to arrest oxidization and ensure proper primer adhesion. The rust treatment must be applied in accordance with label instructions.

## **Primer**

All surfaces must be primed prior to painting with an appropriate rust-inhibiting and/or rust-stabilizing lead-free alkyd oil-based red-oxide primer prior to application of finish coats. The primer must be approved in advance by the City's project manager and must be applied in accordance with label instructions.

## **Application**

### **Color**

The finish color shall be black and a sample must be submitted to and approved in advance by the City's project manager. Coatings shall be applied in accordance with coating manufacturer's instructions.

A minimum of two (2) finish coats of urethane gloss enamel paint shall be applied. All application equipment, tools, pressure settings, and techniques shall be used in accordance with manufacturer's instructions.

Mixing and thinning of coatings, including multi-component materials shall be in accordance with coating manufacturer's instructions. Containers shall be kept closed when not in use to avoid contamination.

The contractor shall not use mixed coatings beyond pot life limits.

After the primer is cured, the contractor shall brush-apply a stripe coat to critical locations on the steel such as welds, corners, and edges using a specified intermediate coat.

Uniformly apply coatings at spreading rate required to achieve specified dry film thickness (DFT).

The application of all coatings, including exterior coatings shall be free of film characteristics or defects that would adversely affect the performance of the coating system and affect appearance.

All work shall be warranted for material and workmanship (peeling or washing) for a minimum of one (1) year.

## **Quality Control**



All applicable codes and standards referenced by the American National Standards Institute (ANSI) and the Occupational Safety and Health Administration (OSHA) and in effect as of the contract date shall govern the restoration by the contractor for completed systems, materials and workmanship. In addition, any applicable federal, state, and local regulations, and codes and ordinances will apply.

The contractor shall comply with all federal, state and local laws, codes and ordinances applicable to the work. The contractor will obtain all permits required in connection with the execution of the work, including a City right-of-way permit before beginning any work associated with this contract.

The contractor shall secure the work sites prior to beginning work and for the duration of the restoration process. The contractor shall restrict all unauthorized vehicular and pedestrian traffic from the worksite. The work site shall remain free of hazards and debris for the duration of the project.

The contractor shall restore the site to the general condition and appearance as it was before the work began.

A purchase order/contract will be issued after insurance is in place. Painting must commence within thirty (30) days of the purchase order issue date and must continue as permitted by weather and special events. All light poles in one area must be painted and the site area restored to its pre-restoration condition before moving to another area.

The City reserves the right to restrict work activities for any time and for any reason. The contractor or his designated representative must be present on the work site at any time work operations are in progress. The contractor must immediately notify the project manager of any difficulty in performing the specified work.

### **Measurement and Payment**

The Repaint Street Light bid item shall be paid for on a per EACH basis. Measurement will be based on the actual number of street lights repainted as determined by actual count. The contract unit price paid per each Repaint Street Light shall include full compensation for all labor, material, equipment, and incidentals for doing all work involved in repainting street lights, complete in place, as shown on the Project Plans and in these Special Provisions, and as directed by the City Project Manager, and no additional compensation shall be allowed therefore.

## **REPLACE EXISTING DAMAGED OR MISSING LIGHT POLE**

### **General**

All work and materials shall conform to the 2018 California State Standard Specifications unless otherwise specified within these Technical Specifications.

### **Order of Work**

City of Fort Bragg  
PWP-00127  
Technical Specifications

The first order of work shall be to place a purchase order for standards, luminaires, and equipment.

## **Foundations**

Portland cement concrete shall contain not less than 470 pounds of cement per cubic yard, except concrete for reinforced pile foundations shall contain not less than 564 pounds of cement per cubic yard.

Foundations for street light poles as shown on the plans shall be a minimum of 24" diameter or square and a minimum of 36" deep. Foundation anchor bolts shall per manufacturers' recommendations. Measurements shall be as shown on Standard plan ES-7B.

## **Standards, Steel Pedestals and Posts**

Street light poles shall be Holophane "Charleston" series pole, with fluted 5" diameter, 14 foot height, black finish, and a 70 Watt Holophane Granville luminaire. The Contractor shall furnish submittals for review and approval prior to placing the order for poles.

The banner brackets and/or mountings will be furnished by the Contractor.

## **Conduit**

When rigid non-metallic conduit is placed in a trench (neither in pavement nor under PCC sidewalk), after the bedding material is placed and conduit installed, the trench shall be backfilled with commercial quality concrete, containing not less than 564 pounds of cement per cubic yard, to not less than 4 inches above the conduit before additional backfill material is placed.

PVC coated rigid conduit and fittings shall be used for stub-ups from six inches below grade to above grade (including elbows from horizontal underground to stub-up). PVC coated rigid conduit and fitting shall be steel with an exterior, factory coated 0.040 inch minimum thickness PVC coating complying with MEMA RN1. Additionally, the conduit and fittings interior and threads shall be factory coated with clear urethane (occidental, Robroy Plasti-Bond or approved equivalent).

Conduit runs shown on the plans to be located behind curbs may be installed in the street, within 3 feet of and parallel to the gutter line of the curb, by trenching as provided below. All pull boxes shall be located behind the curb or at the locations shown on the plans.

After conductors have been installed, the ends of conduits terminating in pull boxes, and in service and controller cabinets shall be sealed with an approved type of sealing compound. Conductor tabs shall be plastic sleeve markers, Thomas and Betts, SM markers; Panduit Clip-on markers, Brady SCO clip sleeves or approved equal.

At locations where conduits is to be installed under pavement and existing underground facilities require special precautions, as described in "Obstructions" of these Technical Specifications,

conduit shall be placed by trenching as provided below.

At other locations where conduit is to be installed by jacking or drilling and if delay to any vehicle will not exceed five (5) minutes, conduit may be installed by the trenching method as follows:

### **Trenching Installation of Conduit**

The location of all conduit placed for this installation shall be coordinated and compatible with the placement of other underground facilities (conduit, structures) which is expected to coincide with this project.

Conduit shall be the rigid non-metallic type. Conduit shall be placed under existing pavement in a trench approximately 2 inches wider than the outside diameter of the conduit to be installed. Trench shall not exceed 6 inches in width. Conduit depth shall not exceed 12 inches or conduit trade-diameter plus 10 inches, whichever is greater, except that at pull boxes the trench may be hand dug to required depth. The top of the installed conduit shall be a minimum of 9 inches below finish grade.

In areas where additional pavement is to be placed, trenching installation shall be completed prior to placing final pavement layer.

The outline of all areas of pavement to be removed shall be cut to a minimum depth of 3 inches with a rock cutting excavator specifically designed for this purpose. Cuts shall be neat and true with no shatter outside the removal area.

The conduit shall be placed in the bottom of the trench and the trench shall be backfilled with commercial quality concrete, containing not less than 564 pounds of cement per cubic yard. Concrete backfill shall be placed to the pavement surface except, when the trench is in asphalt concrete pavement, the top 0.10-foot of the trench shall be backfilled with asphalt concrete produced from commercial quality paving asphalt and aggregates.

Prior to spreading asphalt concrete, paint binder shall be applied as specified in Section 39-4.02, "Prime Coat and Paint Binder," of the Standard Specifications. Spreading and compacting of asphalt concrete shall be performed by any method which will produce an asphalt concrete surfacing of uniform smoothness, texture and density.

All excavated areas in the pavement shall be backfilled, except for the top 0.10-foot, by the end of each work period.

### **Pull Boxes**

Set pull boxes on a crushed rock base six inches thick with horizontal dimensions same as bottom of unit plus six inches all around. Crushed rock shall be  $\frac{3}{4}$  inch maximum size, 1 inch minimum size. Set units parallel or perpendicular with adjacent structures. Install covers flush within finished

paved or concrete surfaces. In unfinished areas, install covers one inch above finished grade. Prior to project completion, clean out debris and dirt in units.

Grout shall be placed in bottom of pull boxes. Pull boxes for the street lighting system shall be per PG&E requirements.

### **Conductors and Wiring**

Conductors shall be per the requirements of PG&E for the street lighting circuits and service conductors.

Splices shall be insulated by Method B.

Conductors shall be spliced as shown in the standard plans except that the type "S" splice shall use the "C" shaped compression connector.

### **Bonding and Grounding**

Bonding and grounding shall conform to the 2018 California State Standard Specifications.

### **Service**

The neutral conductor shall run from the service equipment enclosure to the controller cabinet without splicing to another neutral conductor.

Equipment provided in service enclosures shall be as shown on the plans.

### **Functional Testing**

The Contractor is responsible for repairing any damage to the work due to public traffic until acceptance of the work or relief of maintenance, as provided in Section 5-1.46, "Final Inspection and Contract Acceptance", of the 2018 California State Standard Specifications.

### **Measurement and Payment**

Replace Existing Damaged or Missing Light Pole shall be paid for on a per each basis, which shall include full compensation for including materials, tools, equipment and incidentals and for doing all the work involved in installing the lighting, including but not limited to installation and connection of all electrical conduit, conductors and boxes for the project, trenching and backfill for underground conduit and boxes, coordination with PG&E, furnishing and installing new streetlights and their foundations, stubout for irrigation controller, startup and testing to provide a complete and working electrical system as shown on the plans, as specified herein and in the Technical Specifications, and as directed by the City Project

Manager, and no additional payment will be allowed therefor.

## **INSTALL BOLLARD**

### **General**

The Contractor shall call USA prior to any excavation. Any utilities or structures damaged during excavation and installation of the bollards shall be paid for by the Contractor.

### **Part Specifications**

ASTM A513 Type 1 – bollard post

ASTM A513 Type 5 – bollard ground sleeve & filler piece

### **Performance Requirements**

Bollard will remove completely from the ground sleeve and provide flush surface.

Replace bollard with galvanized filler piece.

### **Submittals**

Submittals document can be found at [www.trafficguard.net](http://www.trafficguard.net) under “document library” or enclosed with bollard purchase. Follow manufacturer’s specifications and installation instructions as required.

### **Quality**

Bollard and ground sleeves must be supplied by TrafficGuard to provide consistent quality in appearance and performance.

### **Delivery, Storage, and Handling**

Inspect materials upon receipt ensure that the correct materials have been received and that they are in good condition.

If not installing immediately, store units to avoid damage from other construction activities and elements.

### **Products**

#### **Manufacturers**

TrafficGuard, Inc., P.O. Box 201, Geneva, IL 60134, Tel 877-727- 7347, Fax 800-814-7194, Website: <http://www.trafficguard.net>

City of Fort Bragg  
PWP-00127  
Technical Specifications

## **Materials**

Bollards supplied should be free from surface blemishes and defects where exposed to view in the finished installation.

Steel Tube: ASTM A513 Type 1, ASTM A513, Type 5

Bollard model shall be "NONLOCKING DROP-IN SERIES RP4501 (RFP4548R & DI4)

## **Fabrication**

After fabrication all units are prepared by removing scale and slag through the sand blasting process.

## **Finishes**

All surfaces are primed with rust & corrosion resistant, zinc rich primer w/ 5,000 hour salt spray performance.

Standard finish, TGIC Polyester outdoor finish RAL1028 Yellow. TGIC Polyester powder definition; meets decorative and functional requirements for gloss retention, physical properties, chemical resistance and weatherability.

## **Execution**

### **Installation**

Comply with manufacturer provided instructions and drawings.

Excavation for ground sleeves through the asphalt surface shall be performed with an asphalt core bit. Excavation of the pier hole shall be made with an auger or similar method to provide minimal impact to the adjacent existing asphalt concrete. Concrete shall be placed within the pier hole and up to the adjacent asphalt grade. Any existing asphalt concrete damaged by the Contractor's operation shall be repaired to match existing conditions.

Ground sleeves should be installed with the top of the sleeve set flush with the finished surface.

Ensure that a minimum of a 3 inch gravel base is put down prior to installation to ensure drainage of the bollard, per installation details.

Bollard should not be inserted into the ground sleeve until it is leveled and fully cured. Attach bollard per manufacturer instructions.

If touch up painting in the field, be careful not to paint moving parts which may restrict the

bollard's proper function.

### **Site Storage and Protection**

Upon receipt of bollard unit(s) all materials should be thoroughly inspected to ensure that all parts are received in good condition.

Store units in a dry location away from possible damage until the time of installation.

### **Measurement and Payment**

The Install Bollard bid item shall be paid for on a per EACH basis. Measurement will be based on the actual number of bollards installed as determined by actual count. The contract unit price paid per each Install Bollard shall include full compensation for all labor, material, equipment, and incidentals for doing all work involved in installing bollards, complete in place, as shown on the Project Plans and in these Special Provisions, and as directed by the City Project Manager, and no additional compensation shall be allowed therefore.

## **BOLLARD STORAGE RACK**

### **General**

#### **Submittals**

Submittals document can be found at [www.trafficguard.net](http://www.trafficguard.net) under "document library" or enclosed with bollard purchase. Follow manufacturer's specifications and installation instructions as required.

#### **Quality**

Bollard storage racks must be supplied by TrafficGuard to provide consistent quality in appearance and performance.

#### **Delivery, Storage, and Handling**

Inspect materials upon receipt ensure that the correct materials have been received and that they are in good condition.

If not installing immediately, store units to avoid damage from other construction activities and elements.

#### **Products**

#### **Manufacturers**

TrafficGuard, Inc., P.O. Box 201, Geneva, IL 60134, Tel 877-727- 7347, Fax 800-814-7194, Website:

City of Fort Bragg  
PWP-00127  
Technical Specifications

<http://www.trafficguard.net>

**Materials**

Bollard storage racks supplied should be free from surface blemishes and defects where exposed to view in the finished installation.

**Execution**

**Installation**

Comply with manufacturer provided instructions and drawings.

Bollard storage racks shall be anchored into existing concrete sidewalk per manufacturers specifications.

**Site Storage and Protection**

Upon receipt of bollard storage rack units, all materials should be thoroughly inspected to ensure that all parts are received in good condition.

Store units in a dry location away from possible damage until the time of installation.

**Measurement and Payment**

The Bollard Storage Rack bid item shall be paid for on a per EACH basis. Measurement will be based on the actual number of bollard storage racks as determined by actual count. The contract unit price paid per each Bollard Storage Rack shall include full compensation for all labor, material, equipment, and incidentals for doing all work involved in installing bollard storage racks, complete in place, as shown on the Project Plans and in these Special Provisions, and as directed by the City Product Manager, and no additional compensation shall be allowed therefore.



# LOCATION MAP:

(N.T.S)



LEGEND:

 WORK AREA

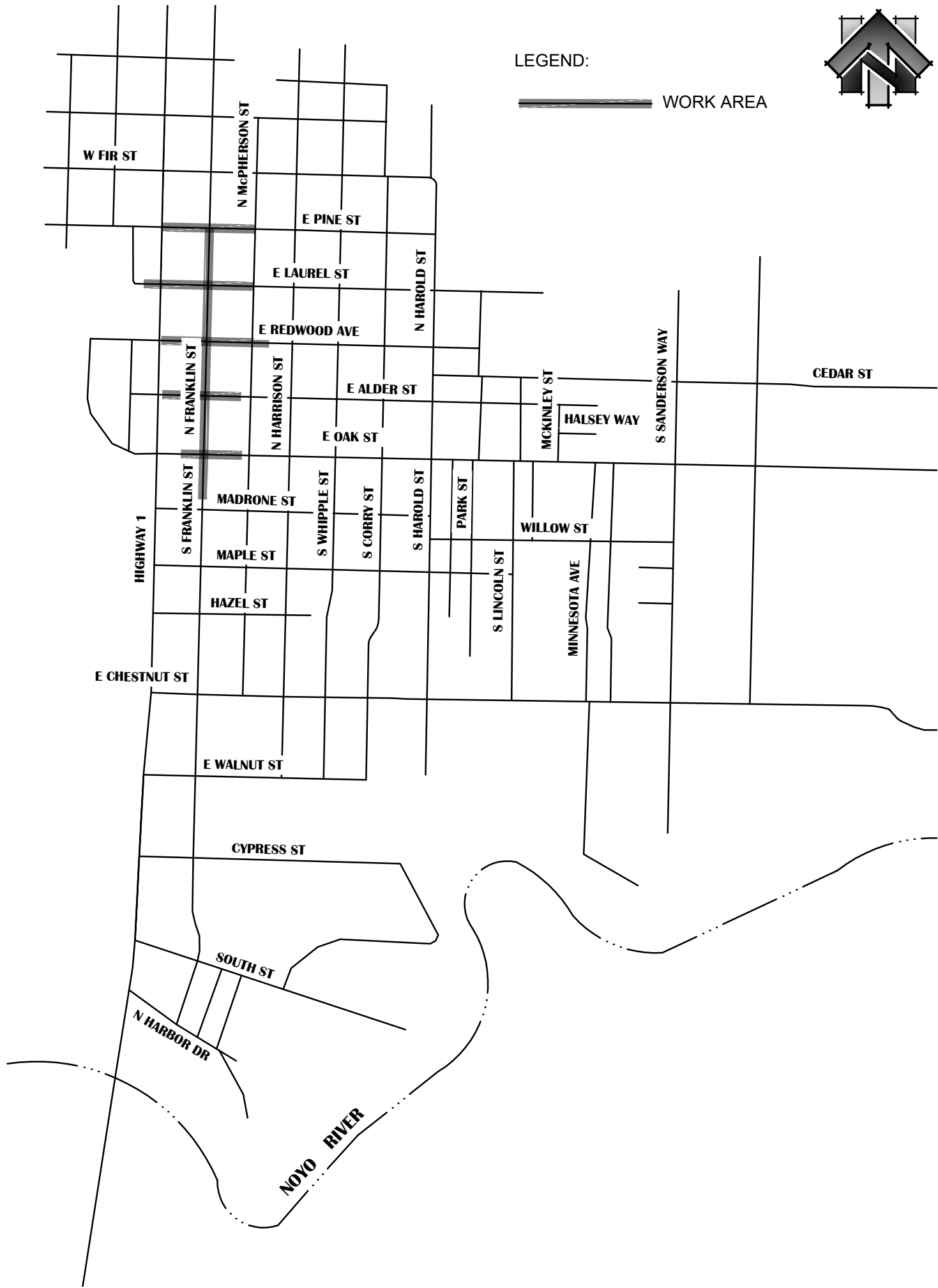

**APPENDIX A**  
**MANUFACTURE'S INFORMATION**



# GENERAL WARNINGS AND CAUTIONARY STATEMENTS FOR REMOVABLE BOLLARDS

In order to safely and effectively use any TrafficGuard<sup>®</sup>, Inc. product, please read and understand the General Warnings and Cautionary Statements contained below. If you have any questions about any of these General Warnings and Cautionary Statements, or about any aspect of TrafficGuard<sup>®</sup>, Inc.'s products or literature, please contact TrafficGuard<sup>®</sup>, Inc. at 877-727-7347, or email [sales@trafficguard.net](mailto:sales@trafficguard.net).



## **BOLLARD SELECTION AND PLACEMENT**

based on vehicle weight, speed and other site specific factors to be determined by owner.



## **FAILURE TO UTILIZE TRAFFICGUARD<sup>®</sup>, INC. AUTHORIZED PARTS, OR MODIFICATIONS**

to the TrafficGuard<sup>®</sup>, Inc. products, or failure to follow the recommended installation procedures, will result in your warranty being null and void.



## **READ AND FULLY UNDERSTAND THE INSTALLATION INSTRUCTIONS**

before attempting to install any TrafficGuard<sup>®</sup>, Inc. bollard product.



## **SUBSTITUTION OF COMPONENTS MAY IMPAIR THE PROPER FUNCTION**

of TrafficGuard<sup>®</sup>, Inc. bollards products. If you need replacement parts, please contact TrafficGuard<sup>®</sup>, Inc. at the number and email above.



**WARNING: FAILURE TO FILL/COVER AN OPEN GROUND SLEEVE ON ALL REMOVABLE BOLLARDS MAY RESULT IN DAMAGE TO VEHICLES OR INJURY TO PEDESTRIANS. ALWAYS FILL/COVER THE GROUND SLEEVE PER TRAFFICGUARD<sup>®</sup>, INC. INSTRUCTIONS.**



## **REPLACEMENT GROUND SLEEVE FILLER PIECES ARE AVAILABLE**

for purchase at TrafficGuard<sup>®</sup>, Inc. For purchase of replacement ground sleeve filler pieces or other components, please contact TrafficGuard<sup>®</sup>, Inc. at the number or email above.



**CAUTION: BOLLARD MUST ALWAYS BE SECURED WITH LOCK MECHANISM WHEN BOLLARD IS IN THE GROUND SLEEVE TO AVOID MISUSE.**



## **FOR MAXIMUM EFFECTIVENESS**

of TrafficGuard<sup>®</sup>, Inc. bollard products, be sure to properly maintain bollards by replacing any damaged, corroded or missing components, and reapply paint as required to maximize visibility. Failure to properly maintain product can negatively impact the bollards performance over time.



## **TO ENSURE VISIBILITY**

of bollards, be sure to apply all decals that are provided with the product, and in the manner recommended by TrafficGuard<sup>®</sup>, Inc.

**IF IN DOUBT CALL TRAFFICGUARD<sup>®</sup>, INC. 877-727-7347**



# INSTALLATION DETAILS

## FOR RP3500 SERIES KEY LOCK REMOVABLE BOLLARDS

- 1 NEVER ATTEMPT TO PLACE THE BOLLARD INTO THE GROUND SLEEVE WHILE IN THE LOCKED POSITION.**
- 2 PAY CAREFUL ATTENTION** to the placement of the location of the ground sleeve latch pin – this determines the location of the lock at the top of the post.
- 3 INSTALLATION OF A SMALLER FOUNDATION** than that specified may reduce the overall impact capacity of the TrafficGuard, Inc. Bollard System.
- 4 TO PROTECT AGAINST A TRIP HAZARD** insert the galvanized ground sleeve filler piece at all times the bollard is removed from the ground sleeve insert.
- 5 PROPER DRAINAGE IS CRITICAL** to the life of the bollard and the locking system. You must keep water from standing in the hole.

**IF YOU HAVE ANY CONCERNS OR QUESTIONS** before beginning the installation please call **TRAFFICGUARD, Inc. 877-727-7347 TOLL FREE.**

4

3

2

1

**NOTE:**  
 - ALL DIMENSION GIVEN IN INCHES.  
 - GRIND AND SMOOTH ALL EDGES, BURRS, AND CORNERS

TOLERANCE -  
 0.X - +/- 0.1 INCHES  
 0.XX - +/- 0.06 INCHES  
 0.XXX - +/- 0.02 INCHES  
 ANGULAR - +/- 1'  
 FRACTION - +/- 1/16

REVISIONS				
ZONE	REV	DESCRIPTION	DATE	APPROVED

USE #3 SCHEDULE 40 STEEL END CAP HEMISPHERICAL DOME  
 NOTE: PREP BOTH THE TUBE AND CAP FOR WELDING - GRIND AND SMOOTH CONTACT SURFACE AFTER WELD.



USE #4 SCHEDULE 40 STEEL END CAP HEMISPHERICAL DOME  
 NOTE: PREP BOTH THE TUBE AND CAP FOR WELDING - GRIND AND SMOOTH CONTACT SURFACE AFTER WELD.



USE #6 SCHEDULE 40 STEEL END CAP HEMISPHERICAL DOME  
 NOTE: PREP BOTH THE TUBE AND CAP FOR WELDING - GRIND AND SMOOTH CONTACT SURFACE AFTER WELD.

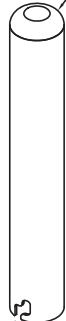

NOTE - BAYONETTE MOUNT ON ONE SIDE ONLY (ALL SIZES)

#3 SCHEDULE 40 STEEL PIPE

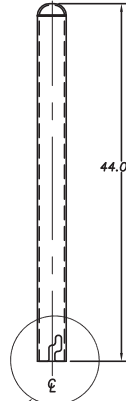

SEE VIEW A

#4 SCHEDULE 40 STEEL PIPE

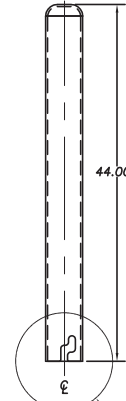

SEE VIEW B

#6 SCHEDULE 40 STEEL PIPE

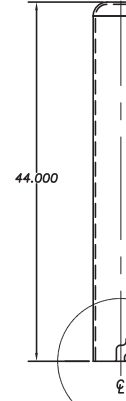

SEE VIEW C

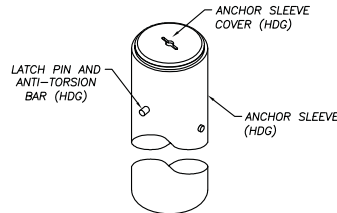
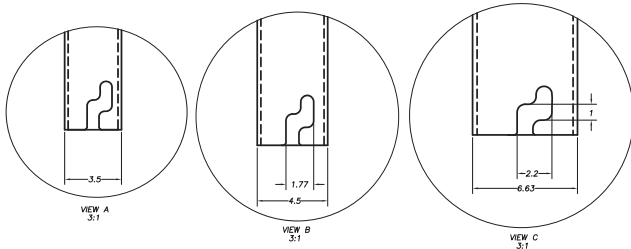

REMOVED POSITION

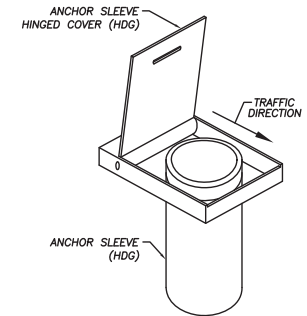
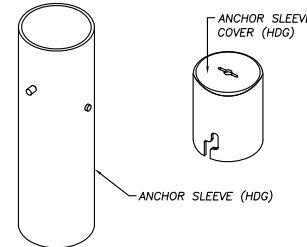

**ALTERNATE ANCHOR SLEEVE, LIDDED GROUND SLEEVE**

**GENERAL SPECIFICATIONS AND NOTES FOR ALL PARTS AND WELDMENTS**

- 1). ALL STEEL WORK SHALL CONFORM TO THE AISC "SPECIFICATION FOR THE DESIGN, FABRICATION, AND ERECTION OF STRUCTURAL STEEL BUILDINGS" - LATEST EDITION UNLESS NOTED ON THE DRAWING.
- 2). ALL WELDING SHALL BE PERFORMED BY QUALIFIED WELDERS AND SHALL CONFORM TO THE AMERICAN WELDING SOCIETY ANSI/AWS D1.1 - LATEST EDITION OF THE STRUCTURAL WELDING CODE - STEEL
- 3). ALL MATERIAL SHALL BE NEW AND SHALL BE AS NOTED ON THE DRAWING AND/OR IN THE BILL OF MATERIAL. SS INDICATES STAINLESS STEEL AND HDG INDICATES HOT DIPPED GALVANIZED STEEL
- 4). ALL PAINTING WORK SHALL CONFORM TO THE MANUFACTURERS SPECIFICATION AND INSTALLATION INSTRUCTIONS AND THE SSPC (STEEL STRUCTURES PAINTING COUNCIL) AND AS NOTED ON THE DRAWING.
- 5). ALL HOLE CENTER DIMENSIONS SHALL HAVE A +/- 1/16 INCH TOLLERANCE AND ALL OTHER DIMENSIONS SHALL HAVE A +/- 1/8 INCH TOLLERANCE UNLESS NOTED ON THE DRAWING.
- 6). ALL WORK SHALL BE PACKAGED AND SHIPPED PER SPECIFIC INSTRUCTIONS BY PARS DIRECT.

THIS DRAWING MAY NOT BE USED OR REPRODUCED EXCEPT WHEN AUTHORIZED IN WRITING BY TRAFFIC GUARD.

TrafficGuard, Inc.  
 P.O. Box 329 Geneva, Illinois 60134  
 Toll Free (877) 727-7247  
 Fax (630) 365-1947

DESIGNER	SCALE	RELEASE DATE	HEIGHT	SHEET	DWG NO	RPT - All post sizes	REV

4

3

2

1

# CONSTRUCTION DATA SCHEDULE RPAS

1. THE DESIGN LOAD IS A STATIC LOAD "P" APPLIED AT 27 INCHES ABOVE GRADE.
2. THE EARTH PRESSURE VALUE IS SHOWN AT DESIGN LOAD AND THE OWNER SHOULD VERIFY THAT THE EARTH IS ADEQUATE TO WITHSTAND THE NOTED EARTH DESIGN PRESSURE.
3. ANCHORAGE SYSTEMS BY OTHERS THAN TRAFFICGUARD,<sup>®</sup> INC. MAY CAUSE PREMATURE FAILURE OF THE BOLLARD.

NOTE: CONCRETE, FORM, ROCK, PVC DRAIN AND REBAR PROVIDED BY OTHERS										
DESIGN LOAD P	BOLLARD		EARTH "Q" MAX.	PIER HT. "C" MIN.	VERT. REBAR		HOOP TIES	PIER CONCRETE	FRENCH DRAIN	PIER "D"
	Out Dia.	Ins Dia.			LENGTH	QTY				
600 #	1.910"	1.620"	992 PSF	42 INCH	38 INCH	3	6 EA.	6 Cu Ft	1.2 CF	8"
1200 #	2.440"	2.064"	1984 PSF	42 INCH	38 INCH	3	6 EA.	6 Cu Ft	1.2 CF	8"
3000 #	3.500"	3.068"	2204 PSF	42 INCH	38 INCH	4	6 EA.	6 Cu Ft	0.5 CF	18"
6000 #	4.500"	4.026"	4408 PSF	42 INCH	38 INCH	4	6 EA.	6 Cu Ft	0.5 CF	18"
6000 #	4.500"	4.026"	2667 PSF	54 INCH	50 INCH	4	7 EA.	8 Cu Ft	0.5 CF	18"
10000#	5.563"	5.047"	4444 PSF	54 INCH	50 INCH	4	7 EA.	8 Cu Ft	0.5 CF	18"
10000#	5.563"	5.047"	3600 PSF	60 INCH	56 INCH	4	8 EA.	9 Cu Ft	0.5 CF	18"
10000#	5.563"	5.047"	2975 PSF	66 INCH	62 INCH	4	8 EA.	10 Cu Ft	0.5 CF	18"
15000#	6.625"	6.065"	3750 PSF	72 INCH	68 INCH	4	9 EA.	11 Cu Ft	0.5 CF	18"
15000#	6.625"	6.065"	3195 PSF	78 INCH	72 INCH	4	9 EA.	12 Cu Ft	0.5 CF	18"
15000#	6.625"	6.065"	3240 PSF	60 INCH	56 INCH	8	8 EA.	25 Cu Ft	1.6 CF	30"
15000#	6.625"	6.065"	3333 PSF	54 INCH	50 INCH	8	7 EA.	32 Cu Ft	1.8 CF	36"

THIS IS A GUIDELINE FOR ESTIMATING, SITE SPECIFIC CONDITIONS SHOULD BE VERIFIED.  
 This Drawing shall not be used nor reproduced except when authorized in writing by TrafficGuard,<sup>®</sup> Inc.

## ROUND POST BOLLARD RPAS ANCHORAGE SYSTEM DETAILS

THIRD ANGLE PROJECTION   
 Do not scale from drawing

Toll Free **TrafficGuard,<sup>®</sup> Inc.**  
 P.O. Box 201, Geneva, IL. 60134  
 Bus: 1.877.727.7347 Fax: 1.800.814.7194

Rev.	Date	by	Description	Action	by	Dwg. Scale:	nts	Assembly Shipping Weight	Drawing Number:
3	-	-	-	Design	wkz	Dwg. Scale:	nts	Varies per Model	RPAS-2
2	-	-	-	Drawn	wkz	Copywrite:	2010	Drawing Date:	12.10.10
1	-	-	-	Checked	wkz	Dwg. Size:	Letter	Sheet:	2 of 2

VEHICLE DESIGN STATIC LOAD "P"  
AT 27 INCHES ABOVE GRADE (NTS)

INSTALL TOP OF CONCRETE AND  
ANCHOR POST AT GRADE

USE NOTED PIER "D"  
DIAMETER SONOTUBE  
IF NEEDED TO AVOID  
CAVE IN AT TOP

ROUND POST ANCHOR  
SLEEVE BY TRAFFICGUARD,<sup>®</sup>  
Inc. AT CENTER OF PIER

4,000 PSI CONCRETE  
PIER AT NOTED  
DIAMETER & HEIGHT

#4 VERTICAL REBAR  
AT NOTED QUANTITY  
& LENGTH.

PVC DRAIN PIPE  
AT LENGTH FROM  
ROCK TO BOLLARD  
AT DIAMETER TO  
MATCH BOLLARD

#3 REBAR HOOP  
TIES AT THE NOTED  
PIER DIAMETER MINUS  
4" WITH 12" TIE LAP  
INSTALLED AT 2" CLEAR  
FROM TOP & BOTTOM  
OF PIER AS SHOWN

3 INCHES MIN.  
THICK ROCK  
FRENCH DRAIN  
PIER BASE.

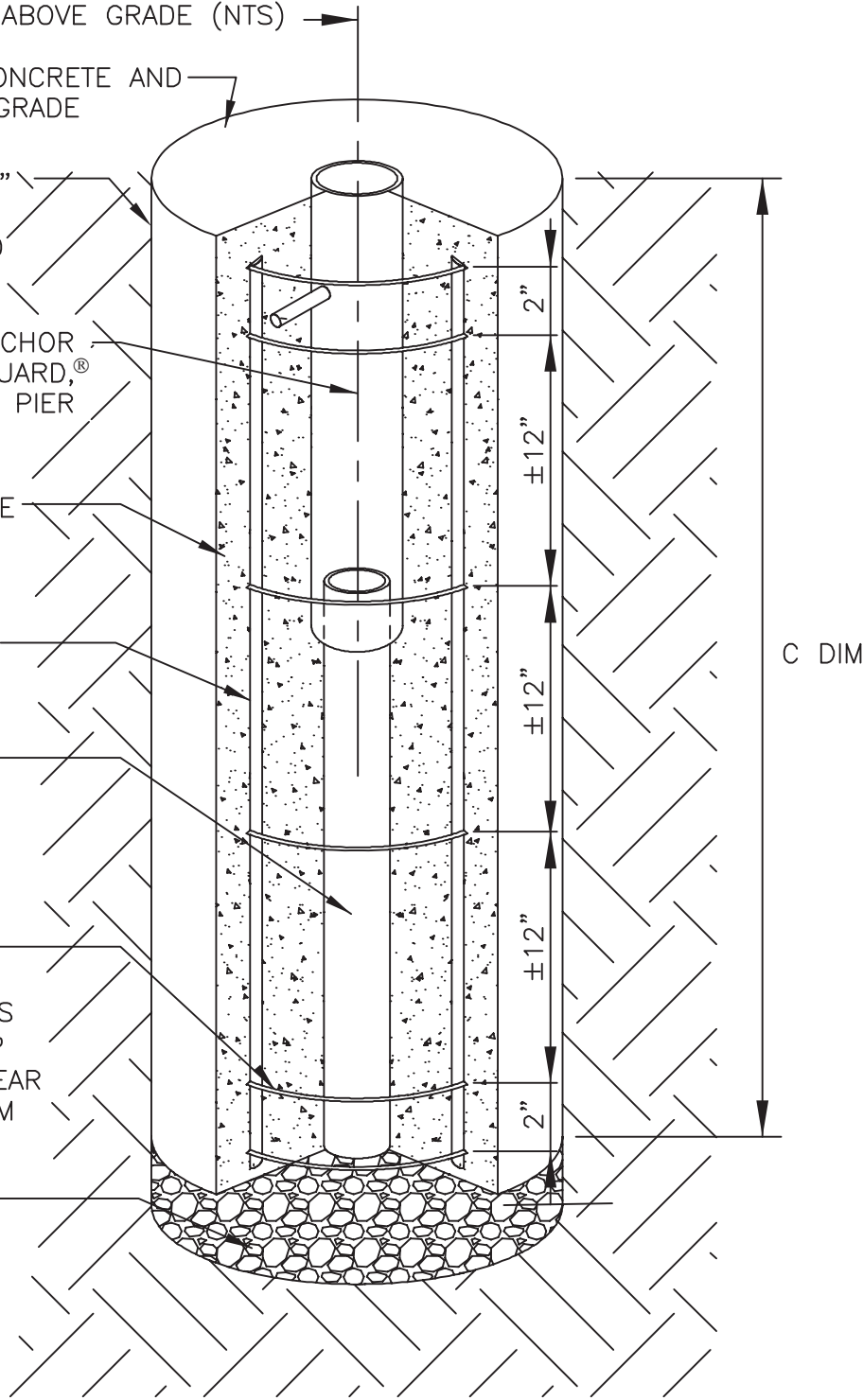

**PIER ELEVATION SECTION**

NOTE REFER TO RPAS-2 FOR THE ANCHORAGE SYSTEM DIMENSIONS, DESIGN LOADS, BOLLARD AND REBAR SIZE, QUANTITIES, AND EARTH PRESSURES THIS IS A GUIDELINE FOR ESTIMATING, SITE SPECIFIC CONDITIONS SHOULD BE VERIFIED.

This Drawing shall not be used nor reproduced except when authorized in writing by TrafficGuard,<sup>®</sup> Inc.

<b>ROUND POST BOLLARD RPAS ANCHORAGE SYSTEM ASSEMBLY</b>				THIRD ANGLE PROJECTION		Toll Free <b>TrafficGuard,<sup>®</sup> Inc.</b>		
				Do not scale from drawing		P.O. Box 201, Geneva, IL. 60134		
3	-	-	-	Action	by	Bus: 1.877.727.7347	Fax: 1.800.814.7194	
2	-	-	-	Design	wkz	Dwg. Scale: nts	Assembly Shipping Weight	
1	-	-	-	Drawn	wkz	Copywrite: 2010	Varies per Model	
Rev.	Date	by	Description	Checked	wkz	Dwg. Size: Letter	Drawing Date: 12.10.10	
							Drawing Number: <b>RPAS-1</b>	Sheet: 1 of 2

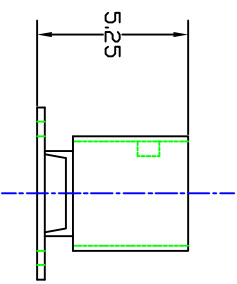
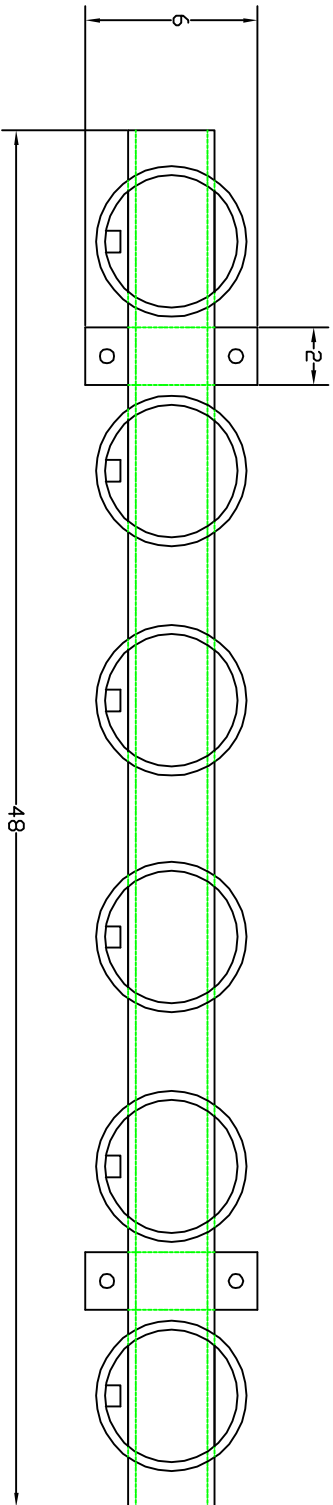
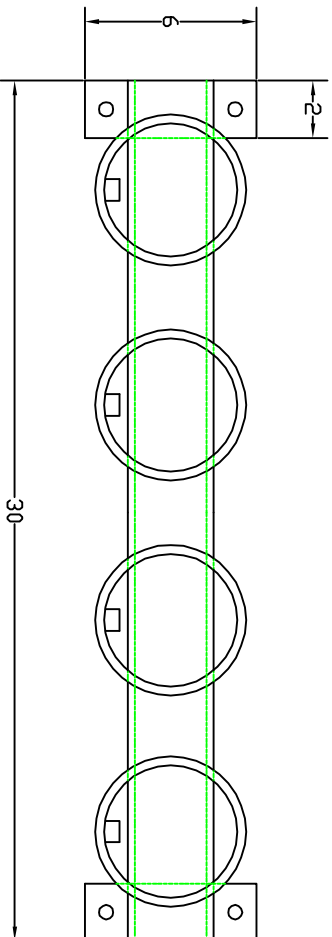
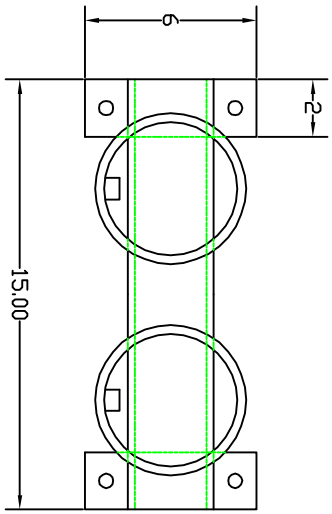

SR4 Series -2, -4, -6







**END OF  
BID DOCUMENT**